

Date Received	Your Name	Organization Representing	Email Address	Address	Comments
03/30/24 9:05 AM	Katharine Aarnio		kaarnio@comcast.net	7668 Lebrun Court	<p>1. Traffic study needs to be more than 1 day and around the time of the school schedules. As earlier as 6am, mid day around lunch time and then again starting at 2pm. We have 4 high schools in close proximity; Rock Canyon, Highlands Ranch, Valor and Skyview.</p> <p>'Traffic Volumes Weekday AM and PM peak hour traffic volumes counts were conducted on Tuesday, December 12, 2023 from 7:00 AM to 9:00 AM and 4:00 PM to 6:00 PM at the study intersections by IDAX Data Solutions.'</p> <p>2. Future planning shows 4 townhomes that will on LT Pkwy across from Marin Ct... what is the projected date of built, what are the lot and home sizes....believe we need more details on these future plans</p>
03/30/24 12:02 PM	Rick Solomon		Dirtbag918@aol.com	9568 La Quinta Drive	<p>No objections to the change of use, as long as existing site access remains unchanged. Strongly recommend that the City: advance consideration of a safer grade separated pedestrian under or overpass of Lincoln aligned with the Wildcat Ridge regional trail (flanking the west edge of this property) and if a school safety zone is to be created, ensure through-traffic on Lincoln is prioritized. When a traffic study is prepared, would appreciate a review of it, engaging CDOT's safe routes to school principles.</p>
04/01/24 8:42 PM	Brian Friedman		Brianjaysfriedman@yahoo.com	10044 Armadillo Drive, Lone Tree, CO	<p>1 - Will the school be providing sufficient parking ONSITE for both Teachers and students of driving age? Will the City of Lone Tree mandate onsite parking only vs teacher and students parking in the neighborhood.</p> <p>2 - Why is the school requesting Teacher Townhomes (aka Multi-family) in a neighborhood without any multi family units? Centennial Ridge and Carriage Club are exclusively single family homes. Townhomes are entirely out of place in the neighborhood and will look out of place. The city should not approve this future request.</p>
04/04/24 8:30 AM	Scott Stene	South Metro Fire Rescue	scott.stene@southmetro.org	9195 E. Mineral	Attached
04/05/24 4:37 PM	Kamyar Mohager		Kamyar.mohager@gmail.com	10380 Carriage Club Drive Lone Tree CO 80124	I believe a private school operating on the site listed in this planned development would cause a significant increase in traffic on Lone Tree Parkway and cause disruption to existing residents
04/05/24 4:43 PM	Ana Engel		ana_engel@comcast.net	10023 Astoria Ct	I am concerned with the traffic impact of changing the church to a school. The intersection where the church is located is the main access to Lincoln to and from Carriage Club, as it has a traffic light. The other access (also to Lincoln) is only practical for turning right (going east). It's almost impossible to turn left since it has no traffic light. So creating traffic congestion at school drop off and pick up times would negatively impact Carriage Club.
04/05/24 4:59 PM	Curt Winn		curtwinn@gmail.com	7475 Pirlot Place	Hello, I have no problem with a school going in. My concern is with traffic. The school is on a corner and I don't want to see the drop off/pickup line extending around the corner on to Lincoln. Also, since the only way to safely leave Carriage Club to eastbound Lincoln is the light at the intersection where the school will be, anything that can be done so that the intersection doesn't get clogged up would be helpful. Thank you
04/05/24 5:16 PM	Rob Knapp		Knapprentals@yahoo.com	7756 Lebrun Ct. lone tree CO 80124	As a 20 year owner in Carriage Club I have always dealt with traffic from the church. The very idea of twice daily traffic to and from a school on Lone Tree parkway would cause a huge amount of traffic. This would definitely make Carriage Club homes loose value. This can not happen. I would be forced to move.
04/05/24 6:10 PM	Vamsee Amara		vamseea@yahoo.com	10139 Longview Dr, Lone Tree, CO 80124	I have a several concerns as a resident of Carriage Club community. It will add significant traffic making it difficult to get out of community and the difficulty on the entire infrastructure (neighborhood park, etc.) will be tremendously negative.
04/05/24 6:13 PM	Karen Tiemeier		Ktiemeier@msn.com	. 10397 Weeden Pl, Lone Tree 80124	This isn't a good location for a school, even a small one. Lone Tree parkway is the only access our neighborhood has to access Lincoln and the light at Lone Tree Parkway is the most efficient way to access west bound Lincoln. We have no other way to go and with the increase in traffic every day for people to pick up and drop off their kids it would backup onto Lincoln. They have the same problem with the Montessori school on University and it's a nightmare traffic situation. Please don't approve this
04/05/24 6:30 PM	S shunk		Sshunk08@comcast.net	7656 Lebrun court	Concerns about traffic. Particularly at light to Lincoln. It's a quick light and there will be traffic back ups. Also concerns about students being allowed to leave during lunch hours and perhaps increased issues with break ins and or mischief. There may need to be another light installed at the other exit of lone tree parkway?
04/05/24 6:44 PM	Kathy Hassoldt		khas50@msn.com	7508 LeBrun CT	Great idea!
04/05/24 7:02 PM	Wayne Williams	Lone Tree homeowner	goodtogo007@aol.com	9938 Bronti Circle	We live right down the street past the park, right off Lone Tree Parkway. We are concerned about the increased traffic flow in our neighborhood already. It is impossible to get onto Lincoln Avenue at Cornerstone (very few cars can turn from Cornerstone onto Lone Tree Parkway to get to the light at Lincoln), and most likely would make a hefty stream of traffic move through our streets in Carriage Club to get to Lincoln going east. It will create a traffic nightmare morning and afternoon, in an already robust traffic area.

04/05/24 7:37 PM	Gary S Cochrane		gsczr1@gmail.com	7855, Arundel LaneArunde	There is only two ways out of Carriage Club. Both on Carriage Club Drive. The West entrance has a traffic light by the planned development and the East entrance only has a stop sign. It is almost impossible to make a left on Lincoln from the East entrance. I would strongly recommend putting a traffic light there. By the way, I bet none of the people who want to move forward on this project live here in Carriage Club. Just saying.
04/05/24 9:15 PM	Kathy Ritter		Renritter87@gmail.com	9935 BRONTI CIR	I am against this amendment and would certainly vote against it.
04/06/24 5:24 AM	Adam Hillard	Carriage Club HOA	Yellowdog337@hotmail.com	7806 Aravon Court	I would like to present a mixed reaction to the proposed change to the Cornerstone Church property. I strongly support the repurposing of the property to convert it to the Ambleside School project. Our community is in such desperate need of quality education opportunities for our children, as the Douglas County Schools have so miserably failed us. In addition, I would strike the plan to include townhomes on the property, or anywhere else in Lone Tree. We have TOO MANY apartments, condos, and townhomes as it is. Lone Tree should focus on decongestion, not adding more congestion. The area suggested for townhomes should be preserved for future school expansion.
04/06/24 6:25 AM	Troy Deering		tdeering002@gmail.com	8008 Witney Place	OPPOSED. Very much opposed to this change. A school of that size will cause significant traffic congestion for the surrounding community attempting to exit the neighborhood via the only traffic light available. The only access west on Lincoln is the stop light which will become unusable and backed up consistently at morning and afternoon school traffic times. This is a significant negative impact versus the current/prior usage, which only occurred one day per week - and not during workweek traffic hours for all other residents.
04/06/24 8:58 AM	Donald Deckard	Resident of Carriage Club	dondeckard@outlook.com	7940 Witney PlaceLone Tree, CO 80124	A private school will attract a student population that needs to be dropped off and picked up causing a traffic mess twice a day on Lone Tree Parkway (our only exit from our neighborhood). It is already congested in the morning without this change. I completely oppose this change!
04/06/24 1:37 PM	Margaret Hutchinson		Peggyhutch@gmail.com	7549 Bantry Court	We do not need any high density housing in that area with the traffic already bad!
04/06/24 2:57 PM	Angela Barela		Ambarela@comcast.net	10220 Dunsford Drive, Lone Tree	As long as school starts AFTER 8am, I do not have an issue. Traffic light is already slow to get on Lincoln. They should not be allowed to interfere or stop regular traffic to accommodate their flow.
04/06/24 7:39 PM	Corinna Robert		corinnamke@aol.com	7518 Lebrun Court, Lone Tree, CO	If the school will pay for a stop light at the other end of Lone Tree Pkwy and Lincoln- so one on the west end and one on the east end of the same street so we can get out of the neighborhood safely then that's the only way I approve.
04/07/24 2:59 AM	Diana McFail		Diana.mcfail@yahoo.com	10510 Lieter place, lone tree 80124	Though I greatly appreciate the intent of this proposed change, as a resident of Carriage Club, I cannot support this proposed change of use for the church. Adding a school of 208 children at this corner would make a traffic nightmare for residents whose only entrances into our neighborhood is along Lone Tree Parkway. That intersection by the church cannot support the volume of cars during pickup and drop off times and the line of cars waiting for turn lights would be ridiculous. If cars proceed to the east entrance of Lone Tree Parkway after drop off/pickup, the line to turn at the stop sign would be incredibly long, especially during busy times on Lincoln, and that's assuming that all cars are turning right. If a car is turning left, it would cause an even bigger backup. Likewise, the turn lanes on Lincoln to turn onto Lone Tree Parkway would be very long as well. I implore you to please deny the request. Thank you for your consideration.
04/07/24 11:13 AM	Cynthia Miller	Carriage club neighborhood resident	georgiapeachy90@gmail.com	7988 Witney PL	A school at this location is going to create traffic that may impede the flow of residents who use this entrance to the subdivision. I do not see how drop off and pick up of 200 students can not create a clog at a widely used intersection which could potentially back up on Lincoln and cause accidents or cause issues with residents trying to leave the neighborhood. Terrible idea for a school at this location. I also think building 4 townhomes on the property is ludicrous. What is the purpose of 4? Makes no sense. Our community is homes. I am opposed to both proposals.....
04/07/24 3:10 PM	Bruce Swedal		bruceswedat@gmail.com	9981 Bronti Circle, Lone Tree 80124	I live in the carriage club community. There are only two entrance/exits into this area. Both enter into Lincoln and only one has a traffic light. With all the development in lone tree over the past several years the traffic along Lincoln has increased to the point that it is extremely difficult getting into and out of our community already. Adding a private school to the only inlet/outlet to the community will dramatically increase traffic during times where traffic is already at its peak. We already need to wait at that light 3to 5 minutes to get through that intersection. Adding more traffic to get 200 students dropped off and picked up from a private school will cause too much hardship to our community. There are other, far better options for kids education.
04/07/24 3:38 PM	Stacy kinder		Stacykinder@comcast.net	10160 Longview dr	Regarding changing cornerstone Church into a school- we are definitely against that. It is hard enough to get out of our neighborhood as it is let alone having the added traffic of even a small school. that is not what is originally zoned for and that's not what we signed up for.
04/07/24 5:36 PM	Michael Ng		medsmkn@hotmail.com	10468 Carriage Club DrLone Tree, CO 80124	As a resident of Carriage Club, I am concerned that the proposed change in use from a church to a school will increase traffic congestion during the hours that residents will need to enter/exit the neighborhood at this intersection. This is an intersection with a traffic signal that allows safe turns onto west bound Lincoln. I was also not able to find the traffic study results.

04/07/24 6:36 PM	Dow Phumiruk		tphumiruk@hotmail.com	10468 Carriage Club Drive, Lone Tree, CO 80124	I believe a school at this corner will cause significant congestion at the intersection of Lone Tree Parkway and Lincoln. It's the only way out of the neighborhood with a stoplight, and I don't support increasing traffic through this corner. Thank you.
04/07/24 6:36 PM	Michael Ng		medsmkn@hotmail.com	10468 Carriage Club Dr Lone Tree, CO 80124	Dow Phumiruk Please disregard my comment about not finding the traffic study - I did find them.
04/09/24 10:38 AM	Cynthia Close		wereclose2you@aol.com	10049 Longview Dr.	I am very concerned about the amount of traffic this project would bring to our neighborhood. I am opposed to allowing a school to be created in this space. We do not have sufficient ingress and egress to allow for the associated traffic. We residents only have one road to our home--Lone Tree Parkway, specifically the single loop south of Lincoln. This is the same road used to access the church parking lot. There is no other access to the church. All students will be driven to school and even with carpooling, there would be at least 150 cars flooding our only ingress and egress at the same time, twice daily. This will prevent us, the residents, from being able to enter or exit our neighborhood without a huge traffic jam. Please do not approve this request for a school. Thank you!
04/09/24 12:40 PM	Roberta Hillard		ralaraway@gmail.com	7806 Aravon Ct	I am not in favor of either of the two parts of this proposed project in this proposed location. First, regarding the townhomes: the immediate surrounding area is all single-family homes, and with most of the recent growth in Lone Tree being multi-family units, it is imperative for Lone Tree to preserve the remaining areas dedicated to single-family homes. Also, allowing townhomes at the entrance to our neighborhood has the potential to negatively affect our property values since it is introducing the multi-family units into an area dedicated to single-family homes, so such a drastic change should not be allowed without a 10-15 year grace period to allow current residents to research and find acceptable alternatives, and sell their current homes before any negative impact. Regarding the school, while I fully support the idea of a private school, this location is not suitable for it due to the enormous congestion it will bring to the neighborhood's only stoplight-equipped exit/entrance twice a day for 9-10 months of the year. The current homeowners and residents of Centennial Ridge and Carriage Club chose to purchase a home and/or live in a home that is not adjacent to a school to avoid the constant congestion a neighborhood school brings. Pre-planned neighborhood schools tend to have much larger parking lots and better ingress/egress than this parcel provides. And with the proposed school being private rather than even a neighborhood school, there is a decreased likelihood of significant attendance by neighborhood families, meaning up to 200+ parents will be dropping off their kids every weekday morning and picking them up every afternoon! That's an additional ~400 visits to our neighborhood every school day! And finally, given the limited parking area and the proximity of this parcel to Lincoln, the twice-daily congestion is likely to spill over onto Lincoln, the busiest thoroughfare through Lone Tree! Besides being a hassle for the commuters trying to get east or west, such congestions brings a huge safety risk with it, as drivers going 45mph may not be prepared to stop on short notice. An additional safety risk is imposed by the parcel being on a slight hill, causing limited line of sight for drivers as well as bright sun right in the line of vision each morning.
04/09/24 12:45 PM	Mark Rankin	Douglas County Assessor's Office	mrankin@douglas.co.us	301 Wilcox Castle Rock, CO 80104	None
04/09/24 12:48 PM	Mark Rankin	Douglas County Assessor's Office	mrankin@douglas.co.us	301 Wilcox Castle Rock, CO 80104	None
04/10/24 1:29 PM	Rick Morris		runningplanet@gmail.com	10010 LONGVIEW DR, LONE TREE, CO 80124	I am very much against this development. The intersection at Lincoln Ave. is a primary ingress/egress into the neighborhood. The additional traffic will cause a dangerous and disruptive situation.
04/11/24 9:08 PM	Trish Morris	Happy Inspirations	trishmorris25@gmail.com	10010 Longview Drive, Lone Tree, CO, 80124, US	I feel that turning the church into a public private school is wrong for the area. The traffic has more than doubled on Lincoln Ave. causing backups and accidents at Lone Tree Parkway. It is the only light that Carriage Club residents have to be able to turn left on to Lincoln Ave. from the subdivision. This is a bad idea and I am firmly against it.
04/12/24 10:29 AM	Shelby King-Grubert		shelbyking@gmail.com	10326 Erin Place	I am concerned that a new school brings a huge amount of traffic (pick-up/drop-off) - as experienced by the school we attend and battle through traffic everyday.
04/12/24 5:07 PM	Paula Ramey		prheritage@aol.com	8050 Witney Place, Lone Tree, Colorado 80124	I'm extremely concerned because of the additional traffic that a proposed school located at Cornerstone Church will cause in the Carriage Club neighborhood. It is proposed that there will be around 200 students (plus teachers, support staff and parent volunteers). The traffic would be impacted 5 days a week mornings and afternoons plus evenings during school programs. In addition if there are school sports, other school teams would play there too.... More traffic. The one light by the proposed school is already slow and traffic is often backed up. The other Carriage Club entrance/exit does not have a light. Currently when vehicles try to turn left out of that exit, it creates an extremely dangerous traffic situation. Drivers wanting to turn right cannot see past the left turning vehicle. Additional school traffic will just make the safety of this intersection even worse. Has there been any consideration to creating a 3rd entrance/exit from the neighborhood? (Maybe on the other side of the neighborhood by McAuthur Ranch?)

04/15/24 3:05 PM	Darrel Palmer		bigdp2010@gmail.com	9918 Bronti Circle, Lone Tree, CO 80124	<p>As a 22 year resident of Carriage Club, I have watched traffic on Lincoln continually increase to the overcrowded street it is today. Adding a school adjacent to Lincoln is only going to make traffic worse twice a day.</p> <p>The danger is real. Look at any school in the metro that is adjacent to a major street and you see huge traffic problems in the morning and afternoon. Those schools that are set back have huge traffic as well but it does not impede the major roadways. The distance from the driveway to Lincoln will not hold many cars while waiting for a light change. This will push traffic into the neighborhood on Lone Tree Parkway as they try to exit the other end on Lincoln without a light. We don't need another light, and we don't need more traffic in the neighborhood.</p> <p>If you insist on approving this change, please prevent the other end of Lone Tree Parkway from being able to turn left without a light. You will need to put in a concrete barrier, not just signage. This should happen with or without the school.</p> <p>I am also against allowing Townhomes on the property. This is being done under the guise of faculty housing. Given the unobstructed mountain view these townhomes would have, I suspect this would become more administrator housing. The townhomes should not be approved. Please see through their plan on this. Those are million dollar views and should not be developed. It's either a school, or it's multi-family housing.</p> <p>In closing, Lone Tree Parkway is in need of maintenance. Adding more traffic does not fix roads or lessen the impact to the neighborhood.</p> <p>Thank you.</p>
04/16/24 11:52 AM	Erik Vik	Southgate Water and Sanitation Districts	reviews@southgatedistricts.org	3722 E Orchard Rd, Centennial, CO 80121	Attached
04/16/24 11:56 AM	Erik Vik	Southgate Water & Sanitation Districts	reviews@southgatedistricts.org	3722 E Orchard Rd, Centennial, CO 80121	Attached
04/17/24 9:13 AM	Lara and Mike Barker	Self	mike.lara.barker1@gmail.com	7659 Lebrun Court, Lone Tree, CO 80124	<p>We think a multi day study should be done for this proposed school. And not in December when schools are in finals and people are not likely to be going into work everyday due to various holiday commitments, and weather that occurs during this time of year. The times for this study, done again, should be between expanded between 6am - 9am, adding lunchtime, and from 2pm - 6pm. We have families in the neighborhood that go to potentially four different high schools in close proximity to the Carriage Club neighborhood. This proposed school would cause potential issues exiting the neighborhood at the corner of Lincoln and Lone Tree Parkway (turning left), when this is already an appalling set of traffic lights when turning left in the direction of Wholefoods Highlands Ranch.</p>
04/17/24 11:56 AM	Charlene Smith	self	charlene5798@aol.com	10150 Longview Dr Lone Tree 80124	<p>I am opposed to the proposed change. Entry and exit of the neighborhood is difficult as it is. The addition of school traffic will make access and exit a nightmare.</p>
04/17/24 2:45 PM	Joe Ott	SSPRD	Jott@ssprd.org	4810 E County Line Rd	Attached
04/17/24 3:19 PM	John Brehmer	Self	Johnbrehmer@hotmail.com	7538 Lebrun Ct	<p>I am opposed to the change due to the safety concerns of additional traffic on an already overly used problem intersection. A school drop off on that portion of the street would be a disaster and poses a safety hazard to the neighborhood residents as well as the parents and children getting dropped off. I am very concerned that this request is starting with 208 Students + support staff and faculty and will be increased in the future. There is no way that this group will plan on staying at such a small enrollment. I believe they are just trying to get a foothold by claiming such a small enrollment and will quickly ramp up to many more kids. This neighborhood is already difficult to exit in the morning and this change will only make it worse.</p>

04/19/24 10:22 AM	Elin Robinson		Elin.m.robinson@gmail.com	7622 Bantry Ct.	<p>At first, I was happy to learn about the proposed development of the former Cornerstone Church into Ambleside School. The building is a perfect size and location for the school and allows for growth of opportunities at the school.</p> <p>However, my biggest concern for turning the former church into a school is the traffic flow at the intersection of Lincoln and Lone Tree Parkway. Because of a lack of funding in the DCSD transportation department, many parents are driving their students to school every day. In addition, the district has instituted a policy where, on a rolling basis, there is no bussing for students one week out of each month. This has increased the daily traffic at this intersection. Where, at one time it was mainly students who drove themselves, now, it is those students plus all the families who must drive their students because of a lack of reliable school transportation.</p> <p>The Project Narrative states that it is anticipated that the proposed school will have less vehicular trips and traffic-related impacts to the surrounding neighborhood. My question is: less than what? Are we to believe that a school that meets Monday through Friday with drop off and pick up times that coincide with other schools in the area is actually going to have less of an impact on the neighborhood than a church with a congregation that meets only on Sundays? I feel that particular piece of the narrative is wildly exaggerated.</p> <p>Before any agreement is reached, I highly recommend an in-depth traffic study be done with particular notice given to traffic flow onto Lone Tree Parkway from the Lincoln/University direction as well as egress from the church onto LT Parkway to the traffic light.</p> <p>In addition, with a stream of cars entering the area at particular times of the day, I believe it might also be appropriate to have an air quality study done to measure the additional impact of CO2 exhaust on the surrounding homes.</p> <p>I think the addition of Ambleside school could be a benefit to our neighborhood, but I do believe there are some significant issues that need to be addressed before this project should commence.</p>
04/22/24 7:33 AM	George Heinert		george.heinert@gmail.com	10087 Andrush CtLone Tree CO 80124	A school at this location will cause traffic congestion. The intersection of Lone Tree Parkway and Lincoln Ave is already a very busy intersection. Also , the property is not zoned for residential use. Four townhomes should not be allowed.
04/25/24 8:22 PM	Steve Gomez		srgg80124@yahoo.com	9914 bronti cr	It is hard enough getting out at the light adding schools students pick up an d dropping kids off will not work...totally opposed to it being a school...It's a church...not a school....
04/26/24 4:45 AM	Fred Guerin	Personal	fredguerin@gmail.com	10045 Teton Ct	My biggest concern with this proposal is the already "speedway" type traffic along the section of Lone Tree Pkwy south of Lincoln Ave. A high percentage of drivers are driving 35-50 mph on this 25mph speed limit section, right past Centennial Ridge Park. Adding school traffic is only going to exacerbate the problem. Speed bumps might help, or maybe some attention from LTPD.
04/26/24 5:20 AM	Adrian & Steve Tidball		steve_adrian@q.com	7740 Barkway Ct.Lone Tree, CO 80124	We are against the school development due to increased car traffic.
04/27/24 10:28 AM	Rebecca and Andrew Cardegna		family@cardegna.com	10390 Weeden PlaceLone Tree CO	We are concerned about the increased traffic and congestion at an already busy intersection. The intersection serves as the best way in and out of several neighborhoods off of Lincoln. The introduction of a school with over 200 students would created chaos and frustration for people who use and rely on that intersection throughout the day.
04/29/24 10:07 AM	David Baker		DavenDenver94@gmail.com	10368 Dunsford DriveLone Tree, CO 80124	I am concerned with the increased traffic each day on the intersection and traffic flow on Lincoln. This intersection is only 1 of 2 available for the residents of Carriage Club to exit onto Lincoln. This intersection currently does have a traffic light whereas the other does not. With the increase traffic flows the ability to access Lincoln will be made more difficult.
04/29/24 1:52 PM	Martha and Roger Sippel	Homeowners in Carriage Club	azuwrite@comcast.net	10524 Dacre Place	Attached
04/29/24 4:29 PM	Frank Kinder		frankkinder@comcast.net	10160 Longview Drive	208 students arriving and assume some siblings, some carpool and possibly a few walking...so assuming about 150 vehicles needing to go through a drop off process in about 20 minutes. The intersection at morning drop off with limited storage will be back up and I predict grid lock situation. I looked over the traffic study and I can't see how that intersection with minimal storage won't be in a failure situation in the morning and afternoon drop off. I'm against the rezoning for that plat of land. If you could limit the students to 120 and have a staggered start for the various grades, just might work???

04/29/24 8:36 PM	John		johnhgo1@gmail.com	10591 Lieter place, Lone Tree Colorado	<p>I am concerned about the extra traffic this will bring on Lone Tree Parkway and Respectfully into Carriage Club. The east entrance into Carriage Club community on Lone Tree Parkway is already so difficult to get in or out without a Traffic signal. If there is going to potentially be a school with up to 200 children that could potentially mean 200+ cars trying to come in and out of Lone Tree Parkway, Monday through Friday. We do not need this extra congestion without some type of mediation or remedy to reduce the already overwhelming congestion. They should consider putting their own entrance to the west of the church for their Proposed school.</p> <p>I would be in favor for the school if they're tax dollars are going to help reduce my property taxes, but they need to find a way to eliminate the traffic which intern could add to the automobile pollution from all of the Excess vehicles that will be coming and going at all times of the day.</p>
04/30/24 5:41 PM	Sean Mentzer		seanmentzer@yahoo.com	9992 Tiburon Ct. Lone Tree, CO 80124	<p>Hello, I am a resident of the Centennial Ridge neighborhood where this current church property is petitioning for a change of use to allow a school to take over the property. I am very concerned about the potential traffic that a school with hundreds of students would introduce. I know a traffic study was submitted, but that seems out of touch with the actual existing traffic much less additional traffic that would be added. The biggest concerns in my mind are the fact that the parking lot is so close to Lincoln, I could very easily see that traffic will back up onto Lincoln itself when all the students are being dropped off in the morning, which would cause backups along at least eastbound Lincoln if not also westbound in the morning when people are trying to commute to work. Additionally, the east end of Lone Tree Parkway is un signaled and given how busy Lincoln already is, that intersection would be absolutely backed up with people attempting to go both east and west on Lincoln both in the morning and evening, again while people are trying to leave the community (with only 2 means of exit) to commute to work. The other concern is that this is a for-profit school, so enrollment will only be increased over time, worsening the traffic situation. Please consider the impact to both the neighborhoods that use these two exits onto Lone Tree, but also traffic along Lincoln in both directions backing up with people trying to pass our area. This proposed change would negatively impact the home values in our area as well as our ability to enjoy the neighborhood during the week, with the only benefit being to the owners of the school itself.</p>
05/01/24 8:18 AM	Dan Coxall	Self	dcoxall@yahoo.com	10046 Genesee Ct. Lone Tree, CO 80124	Attached
05/01/24 3:53 PM	Katie Larson		Katie_Maul@yahoo.com	7753 Barkway Court Lome Tree 80124	<p>I am not in favor of having this rezoned for a school. There is only one way in and out for carriage club and to add morning drop offs and afternoon pickups to be within the neighborhood will cause a large amount of backups on lone tree parkways as well as Lincoln. This can also be a hazard for emergencies that may arise. How the infrastructure is now does not allow this much traffic within those short amount of times without disrupting the neighborhoods everyday flow as well as everyday traffic on Lincoln and still be safe for traffic during emergency situations.</p>
05/01/24 5:20 PM	Shannon Early	Terra Ridge/Lone Tree/Self	shanleary@gmail.com	7530 Indian Wells Pl	<p>I think this school project is not well thought out. They mean well but they aren't thinking of their neighbors outside their own community and organization. I live on the corner of a busy intersection directly across from the building. Air quality is my first concern. This will cause more congestion and more noise. I would prefer this project/school be moved to another location better suited for it.</p>
05/01/24 5:31 PM	Brittany Connolly		bnolconnolly@gmail.com	7510 Indian Wells Place, Lone Tree	<p>My family lives directly across the street from where this school would be and we would be directly impacted in negative ways. We did not move here with the intention of living across from a school with a playground which would create daytime disturbance for work at home parents. This school is not needed in Lone Tree. Eagle Ridge and Lone Tree Elementary are only minutes away from the proposed school and they are free to residents, paid for by our tax dollars. Eagle Ridge just won the John Irwin School of Excellence award- these schools are excellent. The traffic this would cause would be horrendous. It'd be like making the construction at Lincoln and Quebec permanent. This school only benefits a specific religious set, not all of Lone Tree. We neighbors are NOT in favor. Please reject this proposal. We have no need for or desire for a private school.</p>
05/01/24 5:57 PM	Ryan Connolly		Ryanconnollydenver@gmail.com	7510 Indian Wells Pl	<p>My family and I have lived in this neighborhood since 2018 and we love it here. I am strongly against having a school built across the street. I work from home and my window directly points in the direction of the proposed school. Not only would the noise affect my daily work, but it would make traffic worse. Considering traffic is backed up at the intersection of Lincoln and Lone Tree parkway already, I can't imagine how bad it would be with 200+ more people in that area every morning. We have two great, award winning schools in Lone Tree already, and really do not see the need for another.</p>
05/01/24 7:10 PM	Gantuya Brown	Home owner	Egantuya@hotmail.com	7503 rattlesnake dr lone tree co 80124	<p>I am a homeowner residing right next to the parking lot of the property in question. I am against school being built next to where i live. The noise and the traffic associated with the school will be too much of a disturbance for my lifestyle. I vote against this project. Thank you for consideration.</p>
05/01/24 7:30 PM	David A Dean	self	dadean1973@gmail.com	10023 ARMADILLO DR, Lone Tree, CO 80124	<p>The application is lacking detail and support for claims the project would adhere to Lone Tree code and comprehensive plan standards. The application should be deemed incomplete and rejected. Further comments are included in my attachment. thank you for your consideration of my comments!</p>

05/01/24 7:37 PM	David A Dean	self	dadean1973@gmail.com	10023 ARMADILLO DR, Lone Tree CO 80124	The proposed amendment should be denied b/c a public or private school located in planning area A of the planned development would not meet Lone Tree code and comprehensive plan standards, goals, and requirements. The provided application does not provide adequate information, has errors through out, and makes false claims. The application should not be deemed complete and the amendment should be denied. Additional details are included in my attached comments. Thank you for considering my comments.
05/01/24 8:36 PM	Russ McNally		russellmcnally1@gmail.com	9861 Indian wells drive	I do not support this!
05/02/24 7:29 AM	Tony Laleh		21broker@gmail.com	7517 Indian Well Line	I am very concern about the traffic that will add on top of the existing traffic. I think the intersection will be a disaster area.
05/02/24 8:11 AM	Parke W Nimmons		parke@nimmons.com	7528 Indian Wells Lane	I oppose this project due to the increased traffic it will bring to the intersection. The intersection of Lincoln and Lone Tree Parkway is already congested and adding 548 more trips to that intersection will make it more congested.
05/02/24 9:22 AM	Shelly Nimmons	Resident	shelly@nimmons.com	7528 Indian Wells Ln	I live near the intersection of Lone Tree Parkway and Lincoln Avenue. This area cannot handle the additional traffic a school would cause, it's already bad! Please do not allow this to happen.
05/02/24 10:41 AM	Kate Mackey	Individual Household	KateMackey1@comcast.net	9878 Cypress Point Cir, Lone Tree CO 80124	I support allowing the change of use from the church to the private school. There will be more traffic, but the intersection can handle increased traffic easily with some changes to the timing of the stoplight cycle. I believe using the building as a private school will be beneficial to our community.
05/02/24 11:52 AM	ken browder	centennial ridge resident	kw.browder@gmail.com	10013 armadillo dr lone tree co 80124	Regarding the cornerstone church turning to school, We are against this proposal/project...not enough information provided, it will bring the value of the subdivision down.. traffic will be a nitemare for CR residents. DO NOT want to see condos/apt being built there. Please do not consider making this a school or condo/apt complex. Thank you
05/02/24 12:01 PM	ken browder	centennial ridge resident	kw.browder@gmail.com	10013 armadillo dr lone tree co 80124	regarding the cornerstone church turning to school. We are AGAINST this proposal. Traffic will be a nitemare, along with house vales decreasing. Whom ever did this proposal did not give enough information. We were never advised of this proposal, is carriage club been notified. This is a terrible idea. I'm sure there is a better need for this building , other than becoming a school or condo/apt bldg. Thank you
05/02/24 4:17 PM	Kimberly Sherman		kimbarra7536@gmail.com	7536 Indian Wells way	It's already dangerous to cross the street, I've seen people hit, don't need anymore traffic.
05/02/24 5:31 PM	Joe and Becky Carcich	Centennial Ridge residents	mjbiker53@gmail.com	7442 Powderhorn Dr Lone Tree CO 80124	My apologies if this is a duplicate submission, but I had a problem with this site on my initial attempt to comment. I've read that the anticipated peak loads for the involved intersections of Lincoln and Lone Tree Parkway have been studied and have been judged to be within existing design parameters and would stay that way without the proposed site development. Then the study says "Under total future 2025 and 2045 traffic conditions, with development of the site, the intersections within the study area would operate consistent with background conditions." I don't believe it. I think the study was inadequate and naïve to the congestion that would be created with the proposed development, especially with the addition of over 500 new daily trips, particularly at the unsignalized intersection E. Consider northbound traffic that wishes to turn left (west) from Lone Tree Pkwy. Today, it takes only 1 or 2 vehicles to totally backup up multiple cars who wish to turn east, and since it is unsignalized, it often takes minutes to clear. Your study already observes that this intersection is already stressed at peak hours. I can tell you that if only a few of the additional departing vehicles choose to take their chances by swinging over to intersection E and try to turn west, NB traffic will get so constipated that local residents will become prisoners. Dozens of additional vehicle trips at peak hours would be a disaster and back up traffic not only Lone Tree Pkwy (departing vehicles) but arriving vehicles would back up on Lincoln (at both intersections). The stated 548 new weekday total daily trips would be a nightmare for the student vehicles and would be quality-of-life changing for local residents. Without additional road improvements such as additional right turn lane (NB at intersection E), and/or possibly placement of islands that prevent NB left turn at this location, and uniformed police at the signalized intersection, this proposed development must not be approved.
05/02/24 6:05 PM	Bill Clendenning	Lone Tree resident	bclendenning@comcast.net	10039 GENESEE CTLone Tree	Attached
05/02/24 6:07 PM	Bill Clendenning	Lone Tree resident	bclendenning@comcast.net	10039 Genesee CourtLone Tree	Attached
05/02/24 8:13 PM	Mary K Daugaard	Homeowner - Centennial Ridge	mkdaugaard@msn.com	10074 Armadillo Dr, Lone Tree, CO 80124-9719	Attached
05/02/24 8:15 PM	Mary K Daugaard	Homeowner - Centennial Ridge	mkdaugaard@msn.com	10074 Armadillo DrLone Tree, CO 80124-9719	Attached
05/02/24 9:15 PM	Dawn Jewell	Centennial Ridge Homeowners Association	dawnmjewell@yahoo.com	7647 Marin Ct, Lone Tree, CO 80124	See attached
05/02/24 10:21 PM	Dawn Jewell		dawnmjewell@yahoo.com	7647 Marin Ct, Lone Tree, CO 80124	See Attached.

05/03/24 8:57 AM Randolph Rhoads Lone Tree Resident rhoads162000@yahoo.com 7637 Marin Ct.Lone Tree, CO 80124

I am Randolph Rhoads, a long time resident of 7637 Marin Court. I am writing about the Site Improvement Plan Amendment application ZR24-0001, a proposal to allow a change of use at the property at 9941 Lone Tree Parkway to allow for a private school. I am very concerned about the proposed changes for my neighborhood, for I know the effects will be negative.

In the conclusions of the traffic study, the following is stated: "Under total future 2025 and 2045 traffic conditions, with development of the site, the intersections within the study area would operate consistent with background conditions."

This is highly unlikely for the intersection of Marin Court and Lone Tree Parkway, the entrance to the school. During periods of heavy traffic, the nearby intersection of Lincoln Avenue and Lone Tree Parkway would easily back traffic up to block the intersection of Marin Court and Lone Tree Parkway. I've personally observed the traffic backing up in this way during rush hour, as I live close enough to see the intersection. Virtually all traffic exiting the school would need to make a left hand turn onto Lone Tree Parkway. Anybody who has had to make left hand turns against traffic without a signal can sympathize with my assertion. This proposal would eventually require a traffic signal at the intersection of Lone Tree Parkway and Marin Court. Yet the study implies otherwise.

This traffic study deserves more time for critical analysis, as the conclusions appear biased to favor the proposal.

Thank you,

Randolph Rhoads

05/03/24 11:05 AM Stephen J Mikolajczak Centennial Ridge neighborhood stephenmisc@outlook.com 7561 Powderhorn Dr
05/03/24 12:19 PM Mary Kennedy mkennedy624@gmail.com 7657 Marin Ct., Lone Tree, CO 80124
05/03/24 2:54 PM Brad Dau Private Citizen Impacted by Proposed Change of Use bradadau@gmail.com 10075 Teton CtLone Tree CO 80124

Attached

Attached

I generally agree with , and add my voice to, the comments submitted on behalf of the Centennial Ridge HOA which is the neighborhood most impacted by this significant Change of Use proposal. That said, I want to draw additional attention to the impact of this proposal will have on the traffic at Lone Tree Pkwy and Lincoln and especially those vehicles turning left from NB Lone Tree Pkwy onto WB Lincoln at the existing traffic light. Already, the light perhaps allows for at most 7-9 vehicles to turn left and vehicles can queue here for 2-3 minutes if they just miss the light. Currently, there is rarely that many vehicles looking to turn left, save perhaps Sunday mornings. With the proposed number of trips, it will likely mean that dozens of cars will be queuing for the left turn signal during the morning and afternoon peak times. The current location of the Ambleside school would suggest the majority of students live to the the west of the proposed location. This will likely mean that vehicles exiting the proposed school location parking lot will need to turn right and then make a U-turn to join the left turn queue. And even those who intend to turn right to enter EB Lincoln will need to navigate a long line of cars waiting for the left turn signal. I do not believe this is consistent with improved safety for either the attendees/parents of the proposed school or the residents of the Centennial Ridge who are looking to exit the neighborhood. As you know, there is really only one option for going WB on Lincoln when exiting the Centennial Ridge and Carriage Club Estates neighborhoods. And we do not want to encourage more left hand turns at the 3-way intersection of LT Pwky and Lincoln just south of the tennis courts. That turn is already treacherous regardless of the time of day. At minimum, a traffic survey consisting of more than one day (12/12/23) should be conducted to determine as better baseline for traffic impacts. Along with all of the other concerns as detailed in the letter from the CR HOA.

Thank you for the consideration. Brad

05/03/24 7:04 PM John Allen Homeowner junkmail@goteamallen.com 10084 Armadillo Drive

The traffic study associated with the proposed change of use of the existing cornerstone Baptist Church to a private school is concerning as it seems incomplete. The impact to the community would create a burden on the immediate residents. Traffic congestion would not be an acceptable level as described within the study. Furthermore, rezoning of the property for higher volume use by those outside of the residential area would not enhance the community as described within the proposal. This study fails to consider additional use that includes after hours, special events, summer and holiday events. Additionally, there doesn't appear to be any consideration for the impact to increased noise levels or the negative impact to nearby property values.

05/03/24 7:06 PM	John Allen	Homeowner	junkmail@goteamallen.com	10084 Armadillo Drive	The traffic study associated with the proposed change of use of the existing cornerstone Baptist Church to a private school is concerning as it seems incomplete. The impact to the community would create a burden on the immediate residents. Traffic congestion would not be an acceptable level as described within the study. Furthermore, rezoning of the property for higher volume use by those outside of the residential area would not enhance the community as described within the proposal. This study fails to consider additional use that includes after hours, special events, summer and holiday events. Additionally, there doesn't appear to be any consideration for the impact to increased noise levels or the negative impact to nearby property values.
05/03/24 7:40 PM	Jamie and David Cooke	Homeowners in Lone Tree	jamielcooke@yahoo.com	10055 Genesee Court Lone Tree, CO 80124	We are strongly opposed to Planned Development Amendment Applications ZR24-0001 and SP24-0003. The infrastructure at that site is unable to support the substantial increases in traffic and noise that will result if it becomes a school zone. The traffic study that they did was alarmingly insufficient. There are several other incorrect and misleading statements in these proposals that are detailed in the letter that the Centennial Ridge Homeowners Association will be sending to you. We request that you require these proposals to be resubmitted with correct information that represents the actual impact this will have for all residents in our area. Please contact us at 720 456 8434 if you would like additional information.
05/03/24 10:58 PM	Nick Komninos	Our Family	anikmake@gmail.com	7343 Rattlesnake Drive	Attached
05/04/24 9:42 AM	Nick Nimmons	Resident	Nick@nimmons.com	7528 Indian wells lane	There is no room for another school and the increased traffic would create a danger for kids. And I don't know if you've looked around the area but there is no zoom for school busses to come and go. So this idea of a private school in the building is a terrible idea and please do not let this happen.
05/04/24 4:30 PM	Michelle Bennewitz		bennymichelle@hotmail.com	7520 Indian Wells Place, Lone Tree, CO 80124	I am commenting on the proposed school at the former Cornerstone Church. I live directly across the street (to the north) of the property at the corner of Lincoln and Lone Tree Parkway. I am in support of this commuter school. I understand that the current zoning of this property is for a church or multi-family housing (defined - apartments). I am not certain that the HOA or the neighborhood surrounding this property is aware of this particular zoning. I would MUCH rather see a zoning for a school than have a developer decide to build an apartment complex on the property - no matter the size. In my opinion, multi-family housing at this location would bring other issues to the neighborhood that would bring our property values down. Not the school. Our home is also in the neighborhood directly across the street from Thrive Church. Unlike the neighborhood surrounding the proposed school, we experience higher traffic volume from traffic taking a shortcut from Yosemite and Lone Tree Parkway to Lincoln, as well as those who attend Thrive throughout the week. I believe with a well thought out drop-off/pick-up plan for families, traffic flow will be unnoticeable. I am in favor of this rezoning proposal for Amleside School. I wish them the best of luck through this process.
05/04/24 9:41 PM	Eric Lehman		ericjlehman@gmail.com	10081 Astoria Ct. Lone Tree, CO 80124	The location of Cornerstone Church makes this proposal very concerning regarding traffic. Coming out of Carriage Club, it feels very unsafe to turn left on the east side end of Lone Tree Pkwy. So if we want to turn left on Lincoln, the only feasible location is at the light right outside of Cornerstone Church. If you add the drop off and pick up traffic of a new school, right at that location, it would create a nightmare at that light. It would make it a nightmare to leave the neighborhood both in the morning and in the late afternoon, both at times that traffic is already increased. It would potentially create more accidents on Lincoln as people are forced to turn left from the East end of the circle, and decrease the value of our neighborhood due to traffic.
05/05/24 9:47 AM	Nicole Wooton		Nicolette63@hotmail.com	10277 Hexton Ct. lone tree (Carriage Club)	We have concern over traffic and car lines during drop off and pick up. There are two ways out of Lone Tree Pkwy and the exit by the proposed school is the one with the traffic light and therefore much safer to make a left turn (which many people do to get to other schools at pickup/drop off times). There needs to be a very good afternoon plan for cars not to block the area or to get out of that light. Also waiting cars cannot block entrance/exit to school or clog the road. Perhaps there should be a light added to the other exit for Lone Tree Pkwy so the school traffic can be avoided by residents during peak times. Also, 200 cars are not going to be able to exit and fit between the school and the light. How will the traffic be funneled from the lot to the light- wait in the parking lot and then hope the line does not extend beyond the exit of the lot from residents also needing to make a turn at the light on Lone tree pkwy? My kids' car line pick up/drop off is a nightmare and I urge you to have a very very good plan for car line for Both parents at your school and for the residents that will be blocked in if a good plan is not in place for 150-200 cars moving through the area within a 15 minute timeframe twice a day.
05/05/24 6:27 PM	Scott Eskanos		Esky9888@yahoo.com	9888 Falcon Creek Dr Highlands Ranch 80130	I am opposed to this change of use as it will greatly increase traffic and make entrance and exit to my subdivision even more difficult than it already is.
05/05/24 8:56 PM	Jeff Tatnall	Resident of Community	jeffreytatnall@comcast.net	7441 Powderhorn Dr	"Attached"

05/13/24 10:36 AM	Desiree Housek		desireehousek@gmail.com	9534 Las Colinas Dr	<p>This project does not in any way contribute to the community. Lone Tree is a rather small area which is already oversaturated with various religious institutions. The planned development excludes the community as it is of one particular faith, is a private establishment which will have students from other counties commuting here, will not be paying any form of taxes to better enrich our city, and will create excessive traffic issues in an already high traffic area. Do better for the community.</p>
05/17/24 5:52 PM	Rick Solomon	Resident - Terra Ridge (abutting to north)	Dirtbag918@aol.com	9568 La Quinta Drive	<p>I live in Terra Ridge, the neighborhood directly north across Lincoln. Impacts I anticipate are to traffic, and I had requested a copy of the traffic study when available to assess. It has not been provided.</p> <p>Creating a school along a major thoroughfare will impact through traffic, particularly in AM peak hour. Should a school zone be established here, traffic will be slowed to a crawl, similar to what occurs near St Mary's Academy on University. Whereby Lincoln is necked down from 3 lanes to 2, I anticipate through-traffic impacts.</p> <p>Furthermore, students who walk to school will utilize the signal at Lone Tree Parkway, which will need additional crossing (phasing) time also impacting through traffic. To avoid any jaywalking, a fence along Lincoln is recommended to inhibit this dangerous practice.</p> <p>I see no significant impact of the change of use, as long as it is safe. I do not support a new access on Lincoln. The flanking Wildcat Ridge Regional Trail lacks a grade separated crossing of Lincoln, and a functionally safe over or underpass should be considered by the City for both students and recreational users.</p>
05/24/24 3:33 PM	Wynne Shaw	self - Carriage Club resident	wynneshaw@gmail.com	7966 Witney Place, Lone Tree, CO 80124	Attached

SOUTH METRO FIRE RESCUE

FIRE MARSHAL'S OFFICE



Chuck Darnell
Senior Planner
City of Lone Tree
9220 Kimmer Drive, suite 100
Lone Tree, CO 80124
720.509.1273

Project Name: Ambleside School
Project File #: **ZR24-0001 and SP24-0003**
S Metro Review # REFSI24-00049

Review date: 4-4-24

Plan reviewer: Scott Stene
720-989-2249
Scott.stene@southmetro.org

Project Summary: The proposed amendment will permit the use of a public or private school in addition to the already existing uses under the *Centennial Ridge Second Amendment to Planned Development Plan (PD)*, and within Planning Area A. The amendment proposal will allow, if approved, the conversion of the existing church facility into a private, K-12 school by utilizing the floorplan consisting of offices, classrooms, and assemblies for educational purposes. However, it is intended to retain all current land use and standards within the PD for Planning Area A. Future phase(s) of the project will include exterior site improvements to allow for outdoor playing fields, a gymnasium, additional parking and landscaping. Four townhomes for on-site faculty will also be developed. Moreover, the proposed scope of work under the SIP is accommodate the Change In Use of the existing church facility to private, K-12 school use. The proposed improvements to the property consist of a new sidewalk connection from the building to the east, where existing sidewalks are along Lone Tree Parkway. In addition, a new trail connection will be made from the property to the south, where there is an existing trail that connects to a regional trail network.

Code Reference: 2021 International Fire Code, 2021 International Building Code

South Metro Fire Rescue (SMFR) has reviewed the above project and has **conditionally approved** the plans based on the following comments that must be resolved prior issuance of any permits. Applicants and Contractors are encouraged to contact SMFR regarding the applicable permit requirements for the proposed project.

COMMENTS:

1. Fire sprinkler systems for townhomes shall be installed in accordance with the 2021 IRC sections R313.1 and R313.2 and any adopted/amended city ordinance.
2. Student drop off and pick up shall not impede/obstruct fire lanes; provide traffic study/evaluation.
3. One additional fire hydrant is required with the installation of the new gymnasium.
4. Provide auto-turn analysis.
5. An additional point of access may be required when the new gymnasium is constructed; see 2021 IFC section D104.

SOUTH METRO FIRE RESCUE FIRE MARSHAL'S OFFICE



6. Work performed on existing life safety systems (fire alarm, fire sprinkler, underground fire lines, etc.) are deferred submittals and require permits from SMFR. Recommend fire sprinkler evaluation and fire alarm evaluation for expansion into future gymnasium.
7. No Parking Fire Lane signs shall be installed and/or existing signs evaluated for placement; see 2021 IFC section 103.6.
8. Full NFPA 13 fire sprinkler system is required in new gymnasium.
9. Fenced in exterior play area and soccer field shall provide compliant egress and lead to a public way.
10. Existing north fire hydrant shall be accessible to SMFR.

FIRE ACCESS ROAD DESIGN CRITERIA



BUILDING exterior walls (and any portion thereof) of any buildings that are more than 150 feet from the curb line of a public street shall be served by a Fire Apparatus Access Road which shall be unobstructed. This distance is measured by an approved route around the exterior of the building or facility. Additional allowances may be made for some sprinkler protected structures. Alternate access arrangements may be accepted based on site conditions and building fire protection features.

Due to the possibility of heavy vehicle traffic, residential and commercial collector and arterial roads may not be considered adequate for fire suppression operations; no credit for access to perimeter of buildings shall be given from collectors or arterials, unless specifically approved.

Sites not be capable of meeting these requirements and any alternative means must be evaluated and approved by the Fire Marshal.

SOUTH METRO FIRE RESCUE FIRE MARSHAL'S OFFICE



FIRE APPARATUS ACCESS ROADS shall be of an all-weather surface capable of supporting the imposed loads of fire apparatus. Maximum grade on site shall not exceed six percent (6%). Roads shall be asphalt or concrete. Other surfaces may be accepted on a case by case basis.

The minimum unobstructed width of the fire apparatus access road shall be 20 feet. In order to maintain the minimum width and prevent obstructions such as parking of vehicles fire lane signs shall be installed in an approved manner. A minimum vertical clearance of 13 feet, 6 inches shall be maintained for the entire required width of the access road.

Any dead-end access road over 150 feet long shall be provided with an approved turnaround that may be a circle, tee, hammerhead, or other functional approved design.

VEHICLE SPECIFICATIONS are provided for the largest apparatus in use by South Metro Fire Rescue. Fire Apparatus Access Roads shall be capable of accommodating this apparatus.

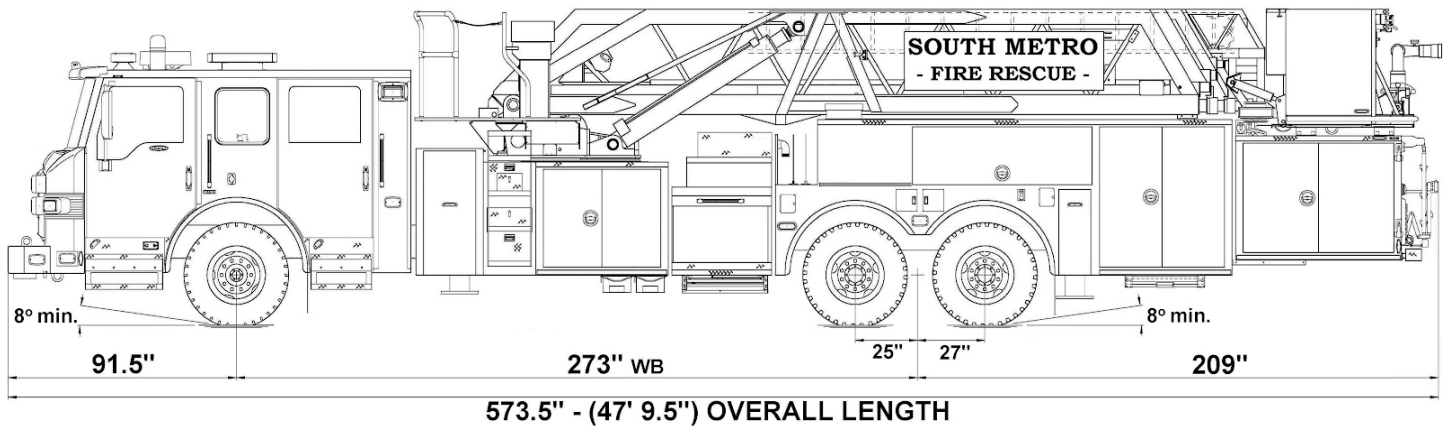

SOUTH METRO FIRE RESCUE FIRE MARSHAL'S OFFICE

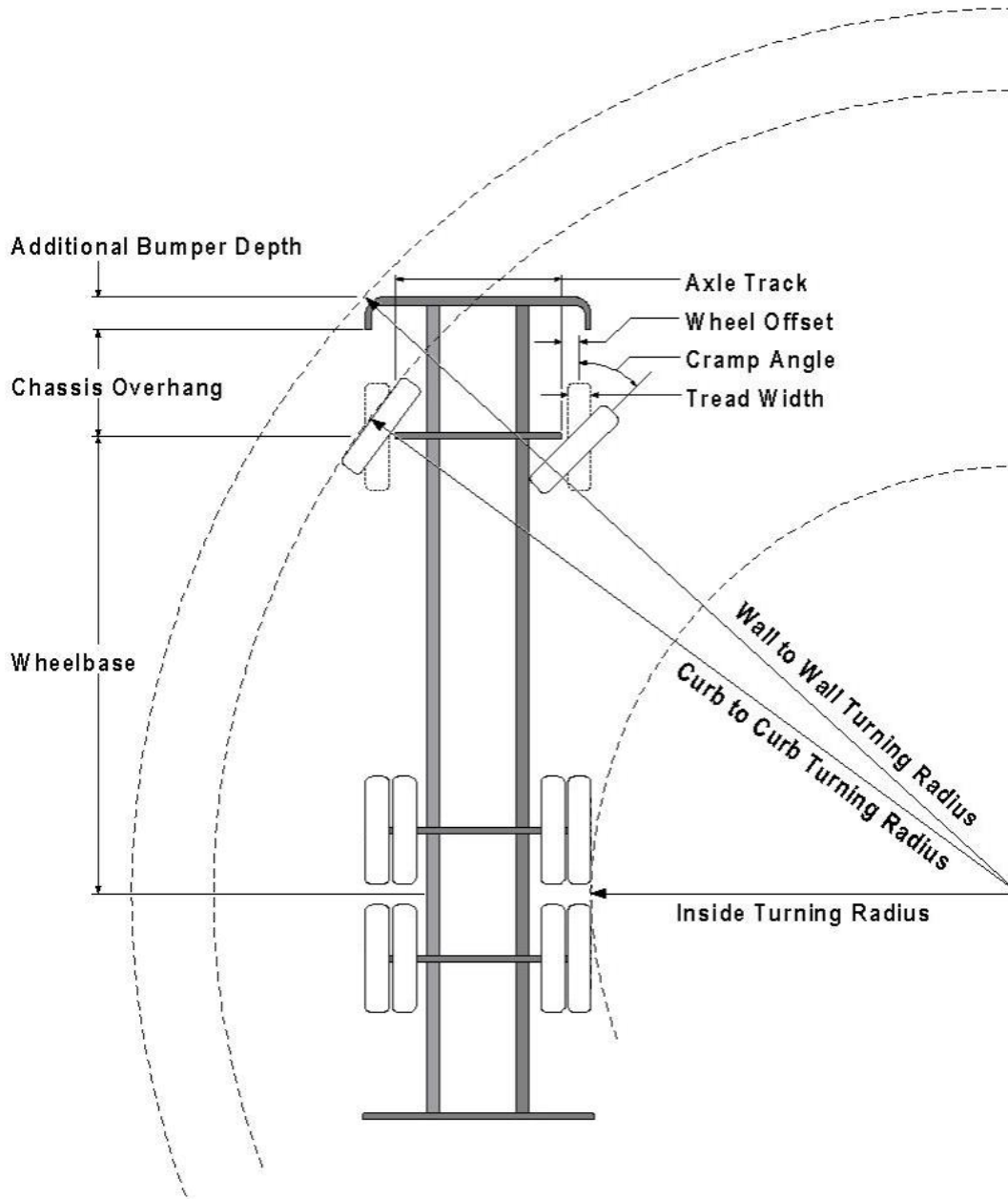

Vehicle Specifications

Length: 47' 9.5"

Width: 8' 5" - (10' 1" mirror to mirror)

Height: 10' 9"

Wheelbase: 273 in.

SOUTH METRO FIRE RESCUE

FIRE MARSHAL'S OFFICE



Design load: 80,000 pounds

Inside Cramp Angle: 40°

Axle Track: 83"

Wheel Offset: 5.3"

Tread Width: 13.5"

Turning Radii:

Inside Turn: 26 ft. 1 in.

Curb to curb: 41 ft. 11 in.

Wall to wall: 46 ft. 8 in.

Where objects are present adjacent to the fire apparatus access road, particularly on turns and turn arounds which require backing, a reasonable safety margin shall be provided to prevent potential damage to the property and to the fire apparatus.

PRIVATE ROADS that provide access to more than two dwellings or one or more commercial buildings shall be constructed to meet the roadway standards approved by the South Metro Fire Rescue Authority for fire apparatus access. Private roads that do not meet the roadway standard may be accepted provided that alternative methods and materials are incorporated into the subdivision that address the fire and life safety of the citizens.

STAMP

NOT FOR CONSTRUCTION

COPYRIGHT
THESE PLANS ARE AN INSTRUMENT OF SERVICE AND ARE THE PROPERTY OF GALLOWAY, AND MAY NOT BE DUPLICATED, DISCLOSED, OR REPRODUCED WITHOUT THE WRITTEN CONSENT OF GALLOWAY. COPYRIGHTS AND INFRINGEMENTS WILL BE ENFORCED AND PROSECUTED.



AMBLESIDE SCHOOL

LINCOLN AVE. & LONE TREE PKWY,
LONE TREE, CO 80124

Date Issue/Description

1	7/31/2023	CONCEPTUAL DESIGN

Project No: XXXXXXXX
Drawn By: KS
Checked By: LM

NEW CONSTRUCTION SITE PLAN

AN100

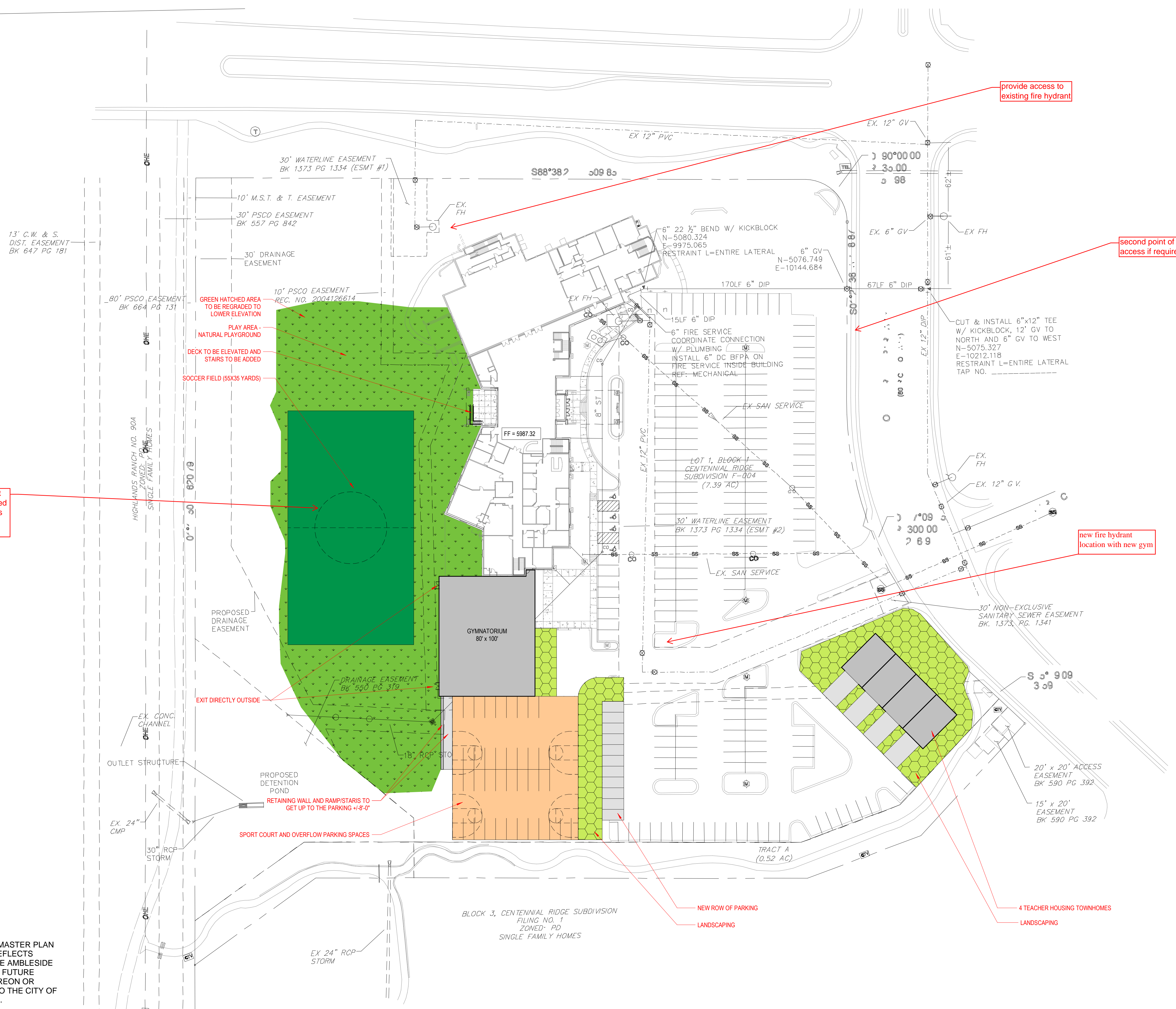

provide compliant egress from fenced play area; all exits shall lead to a public way

provide access to existing fire hydrant

second point of access if required

new fire hydrant location with new gym

NOTE:
THIS CONCEPTUAL CAMPUS MASTER PLAN IS NOT BINDING AND ONLY REFLECTS POTENTIAL BUILD-OUT OF THE AMBLESIDE SCHOOL OF COLORADO. ALL FUTURE IMPROVEMENTS, SHOWN HEREON OR OTHERWISE, ARE SUBJECT TO THE CITY OF LONE TREE MUNICIPAL CODE.

1 NEW CONSTRUCTION SITE PLAN
SCALE: 1" = 40'-0"

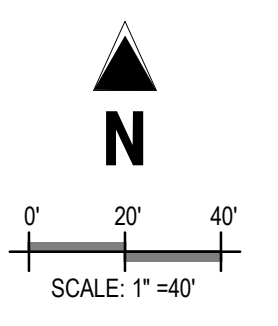

Autodesk Docs/Ambleside School/Architectural/Architectural

7/31/2023 9:41:48 AM

SOUTH METRO FIRE RESCUE

FIRE MARSHAL'S OFFICE



Chuck Darnell
Senior Planner
City of Lone Tree
9220 Kimmer Drive, suite 100
Lone Tree, CO 80124
720.509.1273

Project Name: Ambleside School
Project File #: **ZR24-0001 and SP24-0003**
S Metro Review # REFSI24-00049

Review date: Revised 5-16-24 (see original comments dated 4-4-24 as they still apply)

Plan reviewer: Scott Stene
720-989-2249
Scott.stene@southmetro.org

Project Summary: The proposed amendment will permit the use of a public or private school in addition to the already existing uses under the *Centennial Ridge Second Amendment to Planned Development Plan (PD)*, and within Planning Area A. The amendment proposal will allow, if approved, the conversion of the existing church facility into a private, K-12 school by utilizing the floorplan consisting of offices, classrooms, and assemblies for educational purposes. However, it is intended to retain all current land use and standards within the PD for Planning Area A. Future phase(s) of the project will include exterior site improvements to allow for outdoor playing fields, a gymnasium, additional parking and landscaping. Four townhomes for on-site faculty will also be developed. Moreover, the proposed scope of work under the SIP is accommodate the Change In Use of the existing church facility to private, K-12 school use. The proposed improvements to the property consist of a new sidewalk connection from the building to the east, where existing sidewalks are along Lone Tree Parkway. In addition, a new trail connection will be made from the property to the south, where there is an existing trail that connects to a regional trail network.

Code Reference: 2021 International Fire Code, 2021 International Building Code

South Metro Fire Rescue (SMFR) has reviewed the above project and has **conditionally approved** the plans based on the following comments that must be resolved prior issuance of any permits. Applicants and Contractors are encouraged to contact SMFR regarding the applicable permit requirements for the proposed project.

REVISED COMMENTS:

- 1. Include detailed student drop off/pick up procedures to the deferred emergency evacuation plan permit. See appendix G of traffic impact study. Summary of procedure is as follows: “(1) the staff at Ambleside are present during the full time of drop off and pick up directing parents and children where to go. (2) the driver NEVER leaves their car. If they are doing pick up where they need to leave their vehicle, they will be parking in a designated parking spot. (3) the drop off procedure lasts a total of 20 minutes and again is fully staffed, so in case of emergency the parents will be directed away from the building. And lastly (4) pick up does incur some early queuing, but there will be staff present and the parents are in strict order to**

SOUTH METRO FIRE RESCUE

FIRE MARSHAL'S OFFICE



never park and leave their vehicles, again enabling quick movement and exiting in case of any emergency situations. The parking lot is large enough to get cars away from the fire lane at the building quickly.

2. Revise auto-turn analysis using tower specs provided on sheets 3, 4, and 5.

FIRE ACCESS ROAD DESIGN CRITERIA



BUILDING exterior walls (and any portion thereof) of any buildings that are more than 150 feet from the curb line of a public street shall be served by a Fire Apparatus Access Road which shall be unobstructed. This distance is measured by an approved route around the exterior of the building or facility. Additional allowances may be made for some sprinkler protected structures. Alternate access arrangements may be accepted based on site conditions and building fire protection features.

Due to the possibility of heavy vehicle traffic, residential and commercial collector and arterial roads may not be considered adequate for fire suppression operations; no credit for access to perimeter of buildings shall be given from collectors or arterials, unless specifically approved.

Sites not be capable of meeting these requirements and any alternative means must be evaluated and approved by the Fire Marshal.

FIRE APPARATUS ACCESS ROADS shall be of an all-weather surface capable of supporting the imposed loads of fire apparatus. Maximum grade on site shall not exceed six percent (6%). Roads shall be asphalt or concrete. Other surfaces may be accepted on a case by case basis.

The minimum unobstructed width of the fire apparatus access road shall be 20 feet. In order to maintain the minimum width and prevent obstructions such as parking of vehicles fire lane signs shall be installed

SOUTH METRO FIRE RESCUE FIRE MARSHAL'S OFFICE



in an approved manner. A minimum vertical clearance of 13 feet, 6 inches shall be maintained for the entire required width of the access road.

Any dead-end access road over 150 feet long shall be provided with an approved turnaround that may be a circle, tee, hammerhead, or other functional approved design.

VEHICLE SPECIFICATIONS are provided for the largest apparatus in use by South Metro Fire Rescue. Fire Apparatus Access Roads shall be capable of accommodating this apparatus.

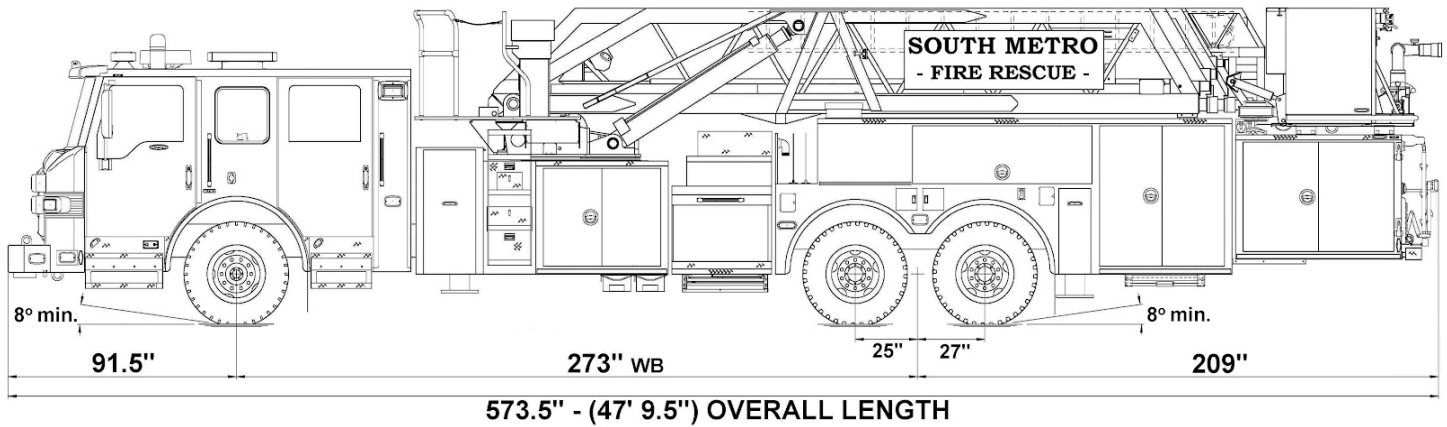

SOUTH METRO FIRE RESCUE FIRE MARSHAL'S OFFICE

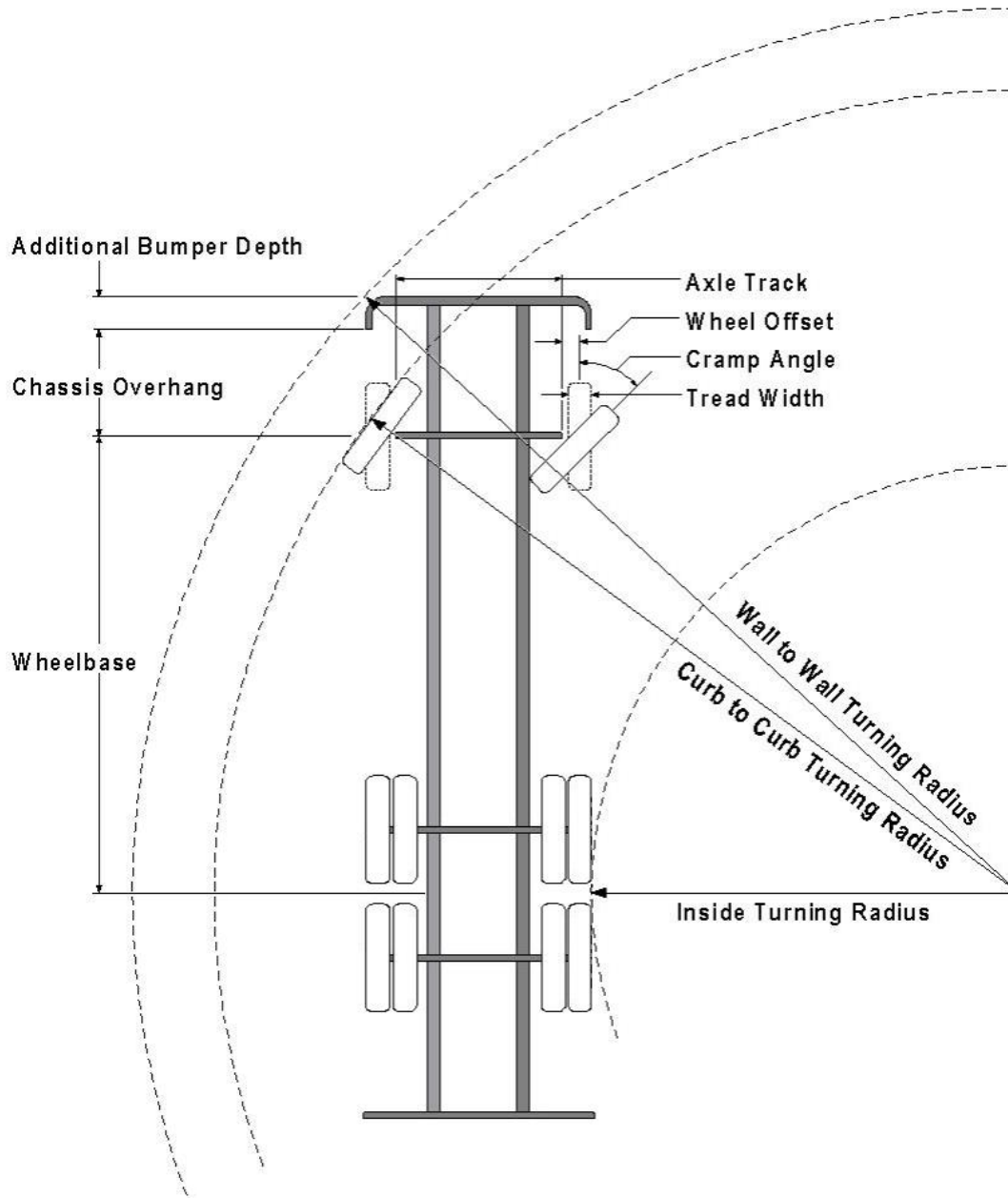

Vehicle Specifications

Length: 47' 9.5"

Width: 8' 5" - (10' 1" mirror to mirror)

Height: 10' 9"

Wheelbase: 273 in.

SOUTH METRO FIRE RESCUE

FIRE MARSHAL'S OFFICE



Design load: 80,000 pounds

Inside Cramp Angle: 40°

Axle Track: 83"

Wheel Offset: 5.3"

Tread Width: 13.5"

Turning Radii:

Inside Turn: 26 ft. 1 in.

Curb to curb: 41 ft. 11 in.

Wall to wall: 46 ft. 8 in.

Where objects are present adjacent to the fire apparatus access road, particularly on turns and turn arounds which require backing, a reasonable safety margin shall be provided to prevent potential damage to the property and to the fire apparatus.

PRIVATE ROADS that provide access to more than two dwellings or one or more commercial buildings shall be constructed to meet the roadway standards approved by the South Metro Fire Rescue Authority for fire apparatus access. Private roads that do not meet the roadway standard may be accepted provided that alternative methods and materials are incorporated into the subdivision that address the fire and life safety of the citizens.



April 16, 2024

Delivered via City of Lone Tree Online Comment Form

Mr. Chuck Darnell
City of Lone Tree
9220 Kimmer Dr
Lone Tree, CO 80124

**RE: Outside Referral – ZR24-0001
Centennial Ridge Planned Development Amendment**

Dear Mr. Darnell,

Thank you for providing Southgate Water & Sanitation Districts (Southgate) the opportunity to comment on the subject referral. Southgate comments are as follows:

1. Southgate's comments pertaining to Centennial Ridge Planned Development Amendment are somewhat generic in nature. For more specific comments pertaining to the redevelopment planned within this project area, see Southgate's referral response to Ambleside School – Change of Use (SP24-0003).
2. As applicable, water and sewer main extensions, fire hydrant, water and sewer service plans, with applicable fees, shall be submitted directly to Southgate for review and approval prior to construction. The design and construction of water and wastewater systems or facilities shall be in strict accordance with Southgate Water & Sanitation Districts' Rules & Regulations and Design & Construction Standards/Specifications. Information on the review process and submittal requirements can be found on Southgate's website: <http://southgatedistricts.org/181/Developer-Information>.
3. Any extensions to Southgate's systems, and any existing mains, are required to be located in public right-of-way (ROW) or an easement without encumbrances and encroachments and minimum required clearances from other utilities, edges of ROW/easement, flow-lines, etc.
 - a. Easement encroachments are not permitted. Encroachments include structures, buildings, fences, walls, retaining walls, parking, curb & gutter crossings, trees, woody plants, nursery stock, planters, islands, medians, posts, signs, etc. All easements shall be drivable with Southgate equipment, including a combination jet/vacuum truck, without traversing encroachments, such as curb and gutter, walkways, landscaping, fencing, etc.
 - b. Unimproved easements shall be a minimum 50' graded for driving

purposes; and, may be landscaped with sod, bark or gravel. Trees, shrubs and woody plants are not permitted.

- c. Improved easements shall be a minimum 30' paved (no pavers or stamped/colored concrete) roadway with a minimum paving width of 30' back-of-curb to back-of-curb or reduced to 26' back-of-curb to back-of-curb with a minimum 4' attached walk.
4. Southgate adheres to the South Platte Renew's (SPR) Pre-Treatment Policy and their Fats, Oils, and Grease (FOG) and Petroleum, Oil, Grease, and Sand (POGS) Programs. FOG and POGS policies can be found at the following website: <https://southplatterenewco.gov>. Review and implement best management practices as necessary. If grease and/or sand/oil interceptors are required per the pre-treatment policies, plans, with applicable fees, must be submitted to Southgate for review and approval prior to construction. The design and construction shall be in strict accordance with Southgate Sanitation District's Rules & Regulations and Design & Construction Standards/Specifications. Information on the review process and submittal requirements can be found on Southgate's website.
5. The cost of providing services to the property, including, and not limited to, System Connection Charges, system extension projects, potential system impact studies, and potential system impact fees, will be borne by the property owner.
 - a. Tap Sale and System Connection Charge information can be found here: <http://southgatedistricts.org/179/Service-Connection-Authorization-Tap-Sal>.
6. The legal ability to provide service continues to exist at the time of connection and has not been limited, restricted or suspended by the action of a governmental entity, agency or other regulatory body which would diminish Southgate's capability to provide such service.
7. Contact Southgate's Engineering Staff as soon as possible to discuss the project and establish project-specific requirements.

You may contact me at reviews@southgatedistricts.org with questions.

Sincerely,



Erik Vik, PE
Southgate Districts Review Coordinator
Vik Consulting, LLC

cc: David Irish, Southgate Water & Sanitation Districts; File



April 16, 2024

Delivered via City of Lone Tree Online Comment Form

Mr. Chuck Darnell
City of Lone Tree
9220 Kimmer Dr
Lone Tree, CO 80124

**RE: Outside Referral – SP24-0003
Ambleside School**

Dear Mr. Darnell,

Thank you for providing Southgate Water & Sanitation Districts (Southgate) the opportunity to comment on the subject referral. Southgate comments are as follows:

1. As applicable, water and sewer main extensions, fire hydrant, water and sewer service plans, with applicable fees, shall be submitted directly to Southgate for review and approval prior to construction. The design and construction of water and wastewater systems or facilities shall be in strict accordance with Southgate Water & Sanitation Districts' Rules & Regulations and Design & Construction Standards/Specifications. Information on the review process and submittal requirements can be found on Southgate's website: <http://southgatedistricts.org/181/Developer-Information>.
 - a. Southgate recommends confirming hydrant and fireline coverage requirements with South Metro Fire prior to submitting plans for Southgate review.
2. Any extensions to Southgate's systems, and any existing mains, are required to be located in public right-of-way (ROW) or an easement without encumbrances and encroachments and minimum required clearances from other utilities, edges of ROW/easement, flow-lines, etc.
 - a. Easement encroachments are not permitted. Encroachments include structures, buildings, fences, walls, retaining walls, parking, curb & gutter crossings, trees, woody plants, nursery stock, planters, islands, medians, posts, signs, etc. All easements shall be drivable with Southgate equipment, including a combination jet/vacuum truck, without traversing encroachments, such as curb and gutter, walkways, landscaping, fencing, etc.
 - b. Unimproved easements shall be a minimum 50' graded for driving purposes; and, may be landscaped with sod, bark or gravel. Trees,

shrubs and woody plants are not permitted.

- c. Improved easements shall be a minimum 30' paved (no pavers or stamped/colored concrete) roadway with a minimum paving width of 30' back-of-curb to back-of-curb or reduced to 26' back-of-curb to back-of-curb with a minimum 4' attached walk.
3. Southgate adheres to the South Platte Renew's (SPR) Pre-Treatment Policy and their Fats, Oils, and Grease (FOG) and Petroleum, Oil, Grease, and Sand (POGS) Programs. FOG and POGS policies can be found at the following website: <https://southplatterenewco.gov>. Review and implement best management practices as necessary. If grease and/or sand/oil interceptors are required per the pre-treatment policies, plans, with applicable fees, must be submitted to Southgate for review and approval prior to construction. The design and construction shall be in strict accordance with Southgate Sanitation District's Rules & Regulations and Design & Construction Standards/Specifications. Information on the review process and submittal requirements can be found on Southgate's website.
 - a. Southgate will require a new, properly sized, GGI per the FOG Policy mentioned above.
4. The cost of providing services to the property, including, and not limited to, System Connection Charges, system extension projects, potential system impact studies, and potential system impact fees, will be borne by the property owner.
 - a. Tap Sale and System Connection Charge information can be found here: <http://southgatedistricts.org/179/Service-Connection-Authorization-Tap-Sal>.
 - b. Southgate records indicate the property previously paid for:
 - i. 6-inch fireline service (September 2012)
 - ii. 1-inch domestic service (April 1997)
 - iii. 2-inch domestic service (March 2013 for addition)
 - iv. 14.59 ERU's for sewer connection charge (April 1997)
 - v. 11.23 ERU's for sewer connection charge (March 2013)
5. The legal ability to provide service continues to exist at the time of connection and has not been limited, restricted or suspended by the action of a governmental entity, agency or other regulatory body which would diminish Southgate's capability to provide such service.
6. Contact Southgate's Engineering Staff as soon as possible to discuss the project and establish project-specific requirements.

You may contact me at reviews@southgatedistricts.org with questions.

Sincerely,

A handwritten signature in black ink, appearing to read "Erik Vik". The signature is fluid and cursive, with the first name "Erik" and last name "Vik" clearly distinguishable.

Erik Vik, PE
Southgate Districts Review Coordinator
Vik Consulting, LLC

cc: David Irish, Southgate Water & Sanitation Districts; File

CENTENNIAL RIDGE
AMBLESIDE SCHOOL
 SITE IMPROVEMENT PLAN - SP24-0003
 JANUARY 2024

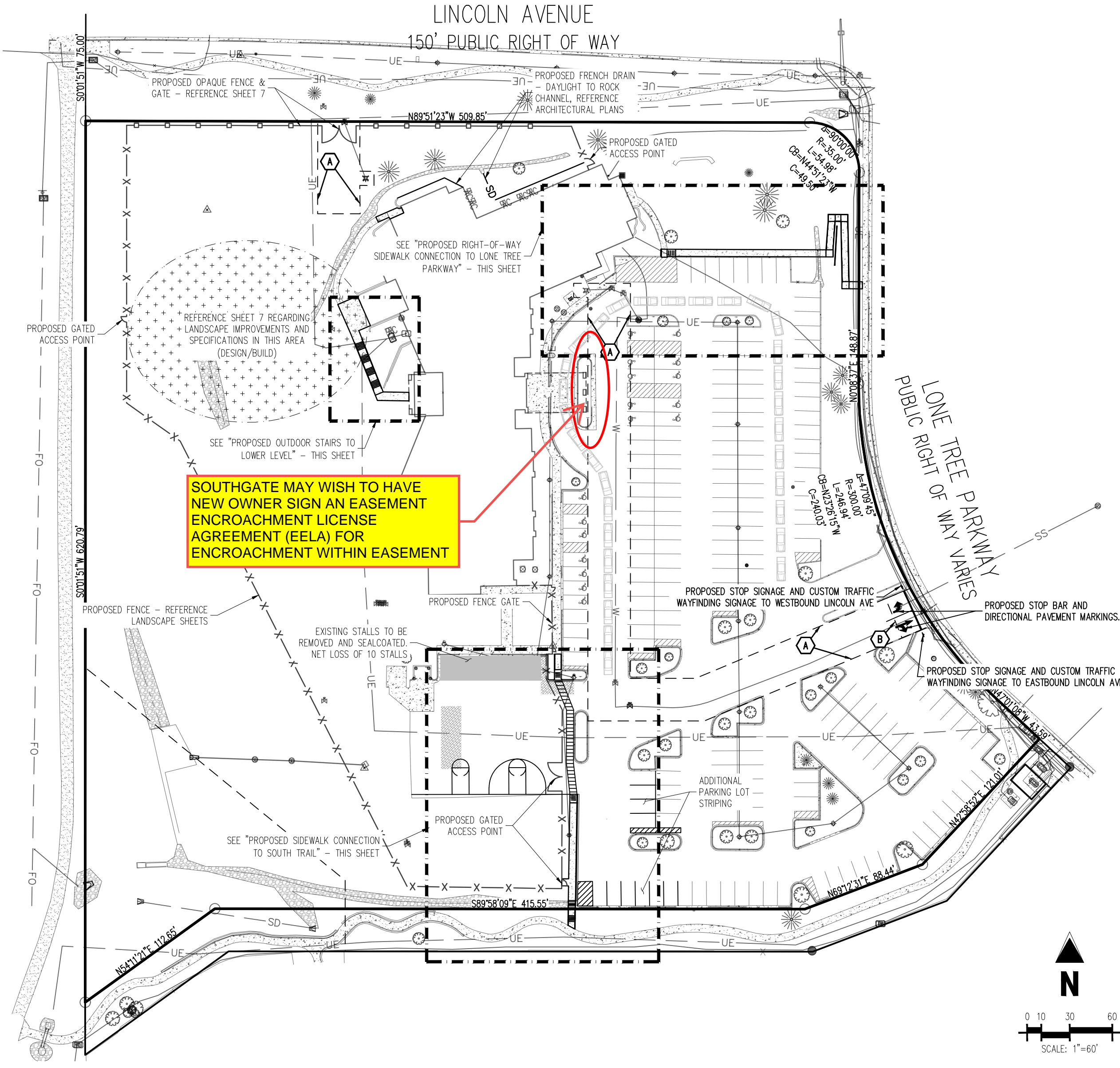

SITE DATA TABLE		
	SQUARE FOOTAGE	% OF GROSS SITE
GROSS SITE AREA	322,138 (7.39 AC)	100%
PERVIOUS AREA	179,388 (4.12 AC)	55%
IMPERVIOUS AREA	142,800 (3.27 AC)	45%
PARKING TABLE		
	EXISTING	PROPOSED
BUILDING AREA (S.F.)	27,358	27,358
REQUIRED STALLS	-	60
STANDARD STALLS	178	175
ADA STALLS	17	17
TOTAL PARKING STALLS	195	188
BICYCLE SPACES	4	4

CITY PARKING CODE REQUIRES PARKING PER THE FOLLOWING:
 PER CODE, BICYCLE PARKING IS 2% OF TOTAL SITE PARKING
 .2 SPACES PER STUDENT (ELEMENTARY SCHOOL)
 .16 SPACES PER STUDENT (MIDDLE SCHOOL)
 .46 SPACES PER STUDENT (HIGH SCHOOL)

PROPOSED PARKING CONDITIONS ARE AS FOLLOWS:
 ELEMENTARY SCHOOL (K-5): 102 STUDENTS - 20.4 PARKING SPACES
 MIDDLE SCHOOL (6-8): 51 STUDENTS - 8.16 PARKING SPACES
 HIGH SCHOOL (9-12): 66 STUDENTS - 31.28 PARKING SPACES
 PER CITY REQUIREMENTS, 60 TOTAL STALLS NEEDED

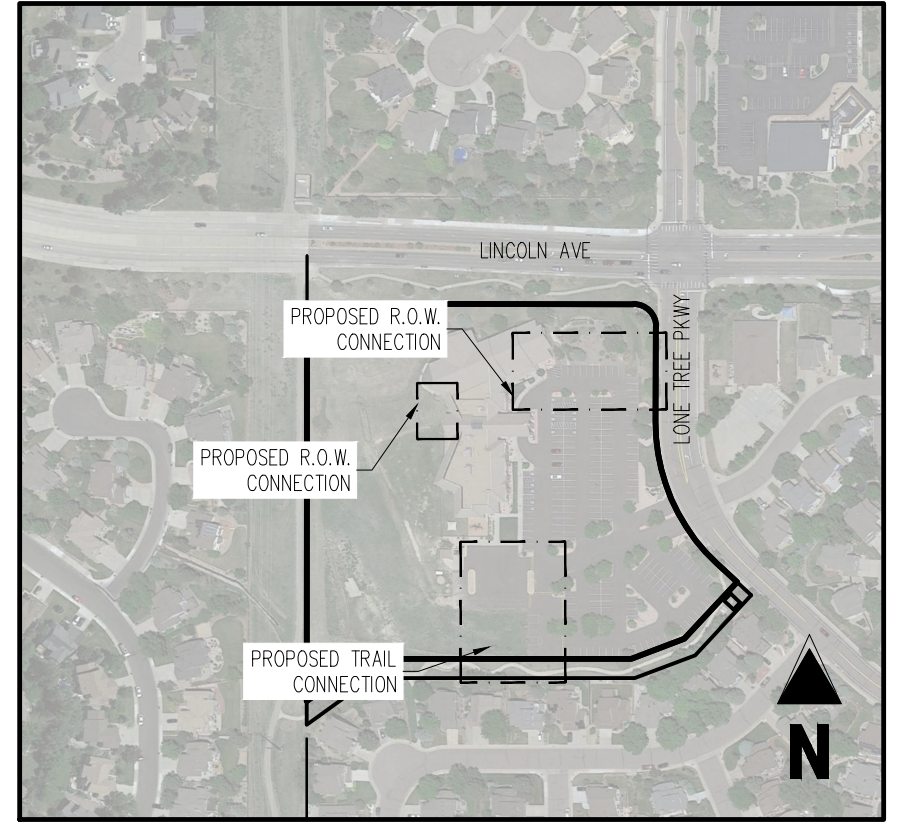

- KEY MAP
 SCALE: 1"=200'
- SITE LEGEND
- PROPERTY BOUNDARY LINE
 - ADJACENT PROPERTY BOUNDARY LINE
 - RIGHT OF WAY BOUNDARY LINE
 - SECTION LINE
 - EXISTING EASEMENT LINE
 - EXISTING TO REMAIN
 - EXISTING WATER LINE TO REMAIN
 - EXISTING FIBER OPTIC LINE TO REMAIN
 - EXISTING UNDERGROUND ELECTRIC TO REMAIN
 - EXISTING FENCE TO REMAIN
 - PROPOSED NEW
 - PROPOSED CURB AND GUTTER
 - EXISTING CURB AND GUTTER
 - PROPOSED SIDEWALK
 - PROPOSED ASPHALT PATCHBACK
 - PROPOSED SEALCOAT
 - ADA PATH OF TRAVEL
 - EXISTING SIGN
 - PROPOSED SIGNAGE

EASEMENT SCHEDULE

- (A) 30' WATER LINE EASEMENT, BOOK 1373, PAGE 1334
- (B) SEWER LINE EASEMENT, BOOK 1773, PAGE 1334
- (C) DRAINAGE EASEMENT, BOOK 330, PAGE 319

SITE SCHEDULE

- (1) PROPOSED CONCRETE RAMP (REFERENCE SITE DETAILS)
- (2) PROPOSED RETAINING WALL (REFERENCE SITE DETAILS)
- (3) PROPOSED CONCRETE SIDEWALK (REFERENCE SITE DETAILS)
- (4) PROPOSED YELLOW PAINTED STRIPING AT 45° AT 2'-0" O.C.
- (5) PROPOSED 2' SIDEWALK CHASE (REFERENCE SITE DETAILS)
- (6) PROPOSED 6" CURB AND GUTTER (REFERENCE SITE DETAILS)
- (7) PROPOSED HANDRAIL
- (8) PROPOSED ASPHALT PATCHBACK (IN PLACE OF EXISTING LANDSCAPE ISLAND)
- (9) PROPOSED BASKETBALL COURT STRIPING
- (10) PROPOSED CONCRETE STAIRCASE (REFERENCE SITE DETAILS)
- (11) PROPOSED CONCRETE LANDING (REFERENCE SITE DETAILS)
- (12) PROPOSED BIKE RACK
- (13) PROPOSED CROSSWALK

SURVEYOR TO OBTAIN AUTOCAD FILE FROM ENGINEER AND VERIFY ALL HORIZONTAL CONTROL DIMENSIONING PRIOR TO CONSTRUCTION STAKING. SURVEYOR MUST VERIFY ALL BENCHMARK, BEARING, AND DATUM INFORMATION TO ENSURE IMPROVEMENTS WILL BE AT THE SAME HORIZONTAL AND VERTICAL LOCATIONS SHOWN ON THE DESIGN CONSTRUCTION DRAWINGS. PRIOR TO CONSTRUCTION STAKING ANY DISCREPANCY MUST BE REPORTED TO OWNER AND ENGINEER PRIOR TO CONTINUATION OF ANY FURTHER STAKING OR CONSTRUCTION WORK.

CONTRACTOR IS RESPONSIBLE FOR PROVIDING ALL INFORMATION FOR FINAL ACCEPTANCE OF WORK FOR ANY LOCAL, STATE OR FEDERAL AGENCY, UTILITY DISTRICT OR ANY OTHER AGENCY OR DISTRICT HAVING APPROVAL AUTHORITY OVER WORK. THIS INFORMATION MAY INCLUDE, BUT IS NOT LIMITED TO, AS-BUILT PLANS, CERTIFICATIONS, INSPECTIONS AND REPORTS.

CONTRACTOR IS RESPONSIBLE FOR AS-BUILT DRAWINGS, TESTS, REPORTS AND/OR ANY OTHER CERTIFICATES OR INFORMATION AS REQUIRED FOR ACCEPTANCE OF WORK FROM CITY, UTILITY DISTRICTS OR ANY OTHER GOVERNING AGENCY.

NOTE: CONTRACTOR SHALL PROTECT ALL EXISTING SURVEY MONUMENTATION. CONTRACTOR SHALL HAVE LICENSED SURVEYOR REPLACE ANY DAMAGED OR DISTURBED MONUMENTATION AT THEIR COST.

NOTE: CONTRACTOR MUST COORDINATE WORK WITH UTILITY COMPANY AND CITY PRIOR TO BEGINNING WORK AND IS RESPONSIBLE FOR ALL MATERIALS, LABOR, REPAIRS, ETC. TO COMPLETE WORK AND RESTORE AREA TO SAME STATE PRIOR TO STARTING WORK.

NOTE: EXISTING SURFACE PIPE FOR ROOF DRAIN CONNECTION SHALL BE TRENCHED AND PLACED WITH A MINIMUM OF 1% SLOPE AT A MINIMUM BURIAL DEPTH OF 12" AND DAYLIGHTED TO NEAREST HILLSIDE TO PROMOTE POSITIVE DRAINAGE AND REDUCE SAFETY HAZARD.

LEGAL DESCRIPTION

A PARCEL OF LAND LOCATED IN THE NORTHWEST 1/4 OF THE NORTHWEST 1/4 OF THE SECTION 16, TOWNSHIP 6 SOUTH, RANGE 67 WEST OF THE 6TH PRINCIPAL MERIDIAN, DOUGLAS COUNTY, COLORADO, MORE PARTICULARLY DESCRIBED AS FOLLOWS:

COMMENCING AT THE NORTHWEST CORNER OF SAID SECTION 16 AND CONSIDERING THE WEST LINE OF SAID SECTION 16 TO BEAR N01°14'50"E WITH ALL BEARINGS CONTAINED HEREIN RELATIVE THERETO:

THENCE S01°14'50"W ALONG SAID SECTION 16, 75.00 FEET TO THE SOUTH LINE OF LINCOLN AVENUE AND THE POINT OF BEGINNING;
 THENCE CONTINUING S01°14'50"W ALONG THE SAID WEST LINE, 657.80 FEET TO A POINT ON THE NORTH LINE OF CENTENNIAL RIDGE SUBDIVISION FILING NO. 1;
 THENCE ALONG SAID NORTH LINE THE FOLLOWING FOUR (4) COURSES:
 1. N55°24'20"E, 124.62 FEET;
 2. S88°45'10"E, 411.36 FEET;
 3. N70°25'30"E, 100.94 FEET;
 4. N44°11'51"E, 128.00 FEET TO A POINT ON THE WEST LINE OF LONE TREE PARKWAY;
 THENCE ALONG SAID WEST LINE THE FOLLOWING FOUR (4) COURSES:
 1. THENCE N45°48'09"W, 73.59 FEET TO A POINT OF CURVE;
 2. THENCE ALONG SAID CURVE TO THE RIGHT HAVING A RADIUS OF 300.00 FEET, A CENTRAL ANGLE OF N01°21'36", 246.94 FEET TO A POINT OF TANGENT;
 3. THENCE ALONG SAID CURVE TO THE LEFT HAVING A RADIUS OF 35.00 FEET, A CENTRAL ANGLE OF S90°00'00", 54.98 FEET TO A LINE OF 75.00 FEET SOUTH OF AND PARALLEL TO THE NORTH LINE OF SAID NORTHWEST 1/4 OF THE NORTHWEST 1/4;
 THENCE N88°38'24"W ALONG SAID LINE 509.85 FEET TO THE POINT OF BEGINNING, EXCEPT THE REAL PROPERTY DESCRIBED IN THAT CERTAIN PARTIAL RELEASE OF DEED OF TRUST RECORDED AUGUST 14, 1985 IN BOOK 590, AT PAGE 392X, COUNTY OF DOUGLAS, STATE OF COLORADO.

CAUTION - NOTICE TO CONTRACTOR

1. ALL UTILITY LOCATIONS SHOWN ARE BASED ON MAPS PROVIDED BY THE APPROPRIATE UTILITY COMPANY AND FIELD SURFACE EVIDENCE AT THE TIME OF SURVEY AND IS TO BE CONSIDERED AN APPROXIMATE LOCATION ONLY. IT IS THE CONTRACTOR'S RESPONSIBILITY TO FIELD VERIFY THE LOCATION OF ALL UTILITIES, PUBLIC OR PRIVATE, WHETHER SHOWN ON THE PLANS OR NOT, PRIOR TO CONSTRUCTION. REPORT ANY DISCREPANCIES TO THE ENGINEER PRIOR TO CONSTRUCTION. **Call before you dig.**

2. WHERE A PROPOSED UTILITY CROSSES AN EXISTING UTILITY, IT IS THE CONTRACTOR'S RESPONSIBILITY TO FIELD VERIFY THE HORIZONTAL AND VERTICAL LOCATION OF SUCH EXISTING UTILITY, EITHER THROUGH POT-Holing OR ALTERNATIVE METHOD. REPORT INFORMATION TO THE ENGINEER PRIOR TO CONSTRUCTION.

Galloway

5500 Greenwood Plaza Blvd., Suite 200
 Greenwood Village, CO 80111
 303.770.8884
 GallowayUS.com

COPYRIGHT
 THESE PLANS ARE AN INSTRUMENT OF SERVICE AND ARE THE PROPERTY OF GALLOWAY, AND MAY NOT BE DUPLICATED, DISCLOSED, OR REPRODUCED WITHOUT THE WRITTEN CONSENT OF GALLOWAY. COPYRIGHTS AND INFRINGEMENTS WILL BE ENFORCED AND PROSECUTED.



AMBLESIDE SCHOOL
 LINCOLN AVE & LONE TREE PKWY
 SITE IMPROVEMENT PLAN - SP24-0003
 9941 LONE TREE PARKWAY
 LONE TREE, CO 80124

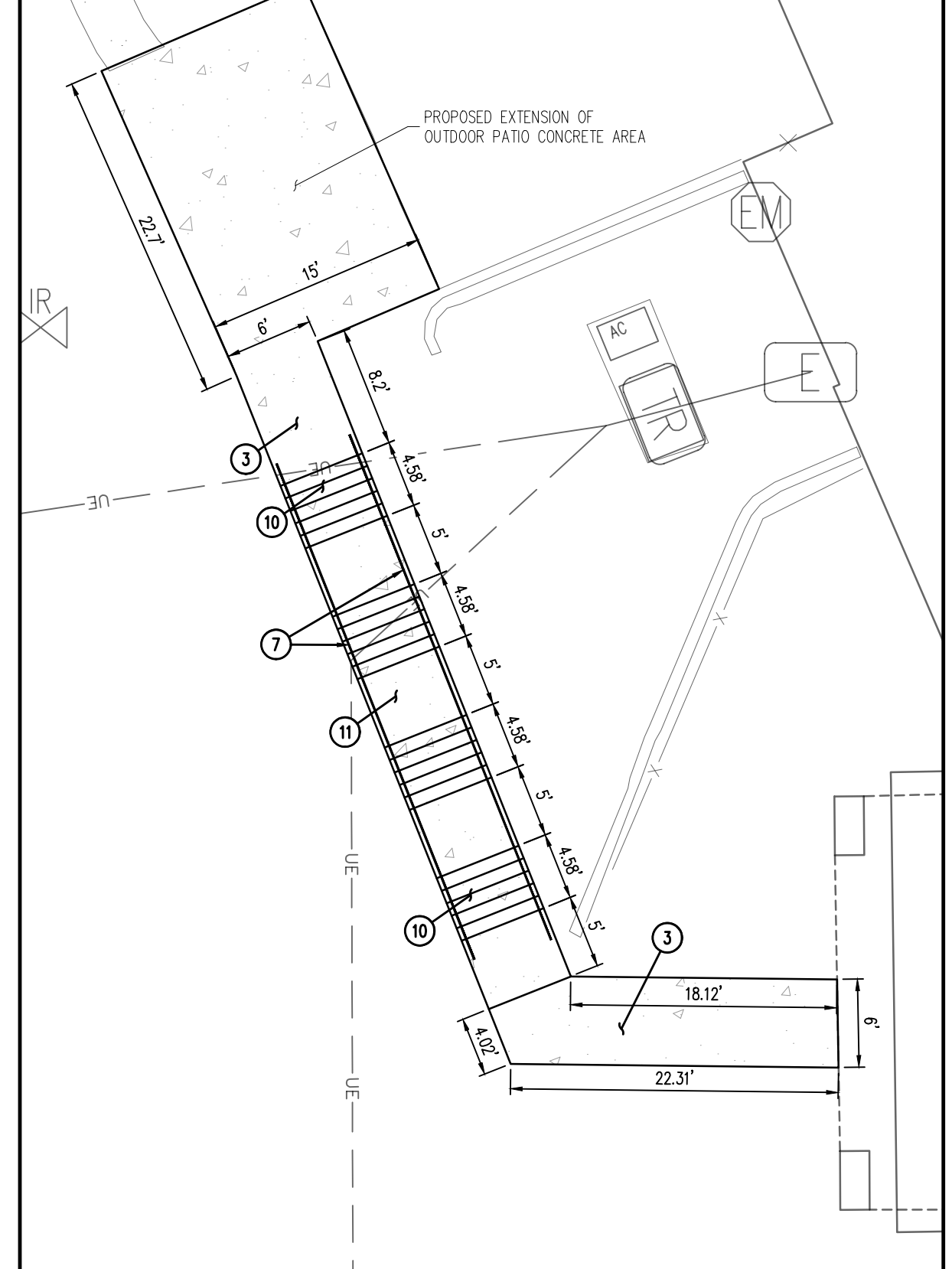

PROPOSED OUTDOOR STAIRS TO LOWER LEVEL
 SCALE: 1"=10'

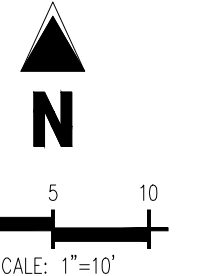

OVERALL SITE
 SCALE: 1"=60'

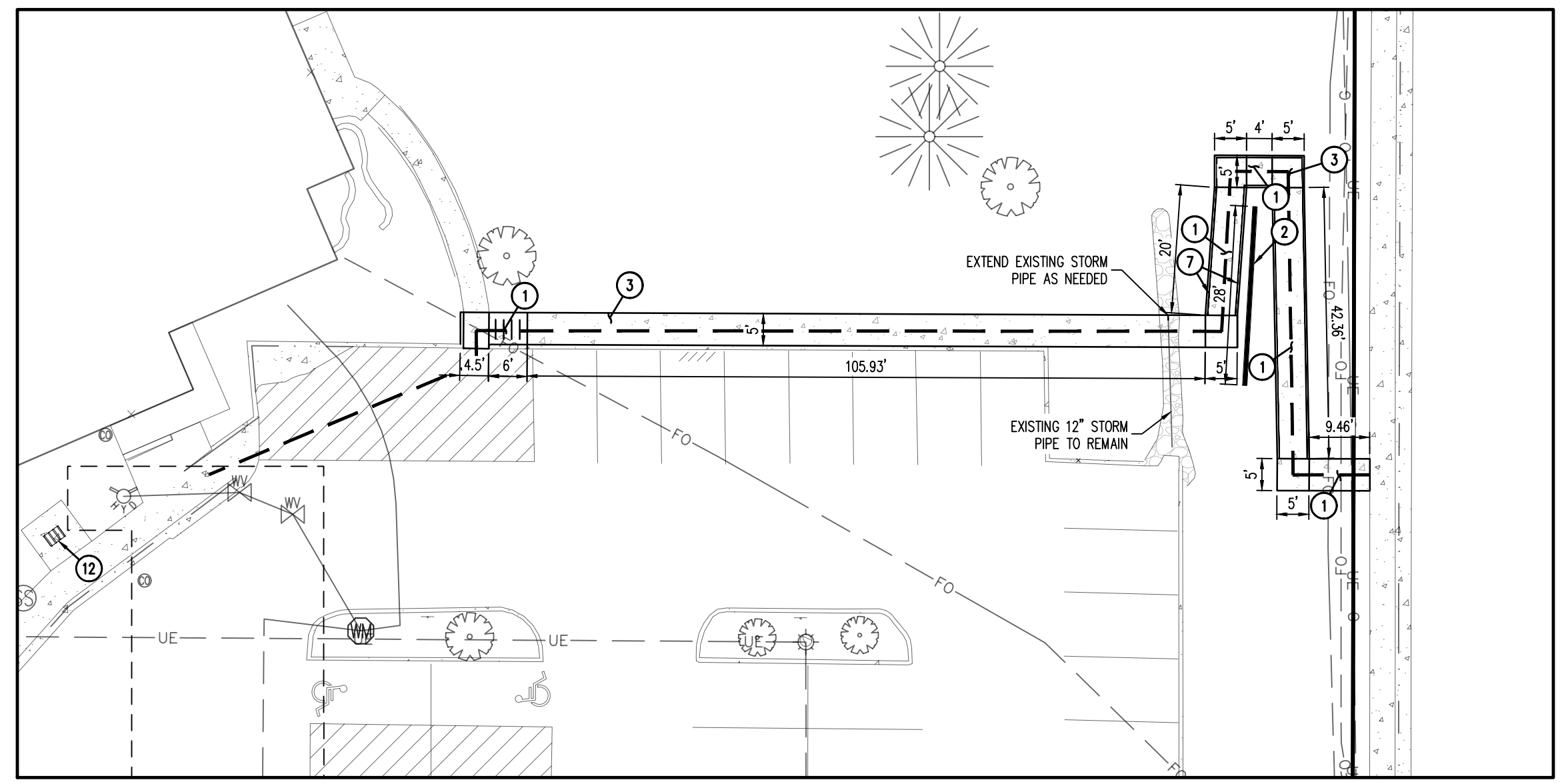

PROPOSED RIGHT-OF-WAY SIDEWALK CONNECTION TO LONE TREE PARKWAY
 SCALE: 1"=10'

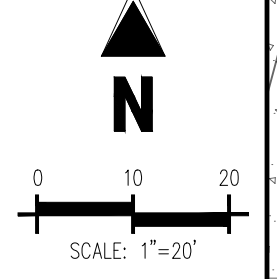

PROPOSED SIDEWALK CONNECTION TO SOUTH TRAIL
 SCALE: 1"=20'

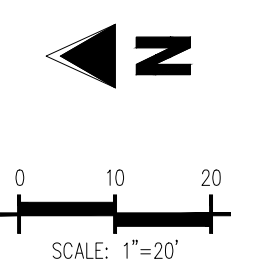
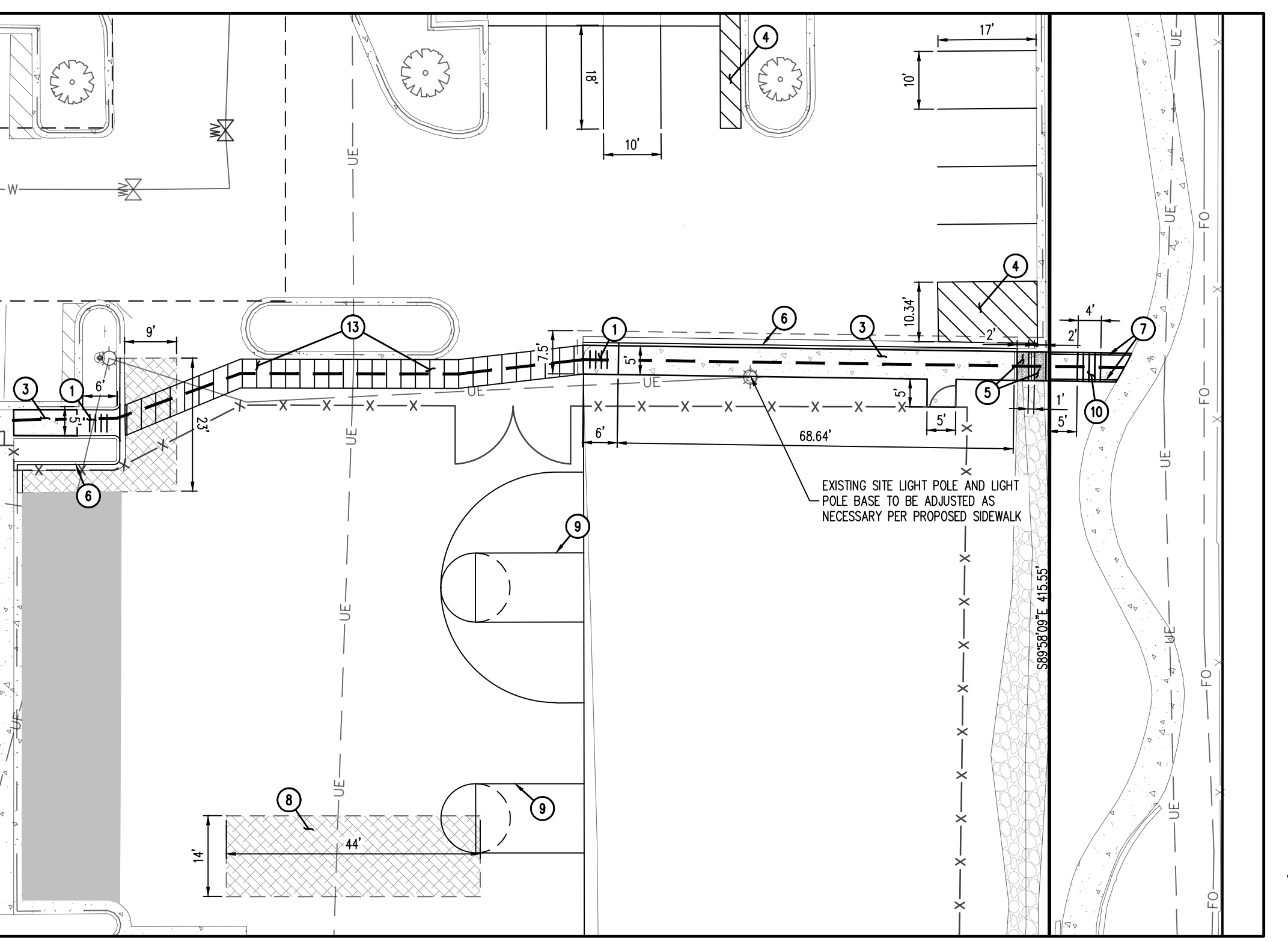

1/25/2024 10:58 AM (GMT-7) - SP24-0003 - Ambleside School - 24113 - 1/25/2024 10:58 AM (GMT-7) - SP24-0003 - Ambleside School - 24113 - 1/25/2024 10:58 AM (GMT-7) - SP24-0003 - Ambleside School - 24113 - 1/25/2024 10:58 AM (GMT-7) - SP24-0003 - Ambleside School - 24113

#	Date	Issue / Description	Init.
1	01/19/24	1ST SUBMITTAL	JSB
2	03/13/24	2ND SUBMITTAL	JSB

Project No: AMCO00002
 Drawn By: DMH
 Checked By: JSB
 Date: JANUARY 2024

SITE PLAN



4810 East County Line Road
Littleton, CO 80126
303.483.7026

April 17, 2024

Chuck Darnell, Principal Planner
City of Lone Tree, Community Development Review Team
9220 Kimmer Dr., Suite 100,
Lone Tree, CO 80124

Re: Referral Response - SP24-0003 & ZR24-0001 – Centennial Ridge Planned Development District, 2nd Amendment

Dear Chuck,

South Suburban staff reviewed the referral for the SP24-0003 & ZR24-0001 – Centennial Ridge Planned Development District, 2nd Amendment and have the following comments.

- Show the existing trail easement on the southeast corner of the property in the plan set.

Thank you for the opportunity to comment on the SP24-0003 & ZR24-0001 – Centennial Ridge Planned Development District, 2nd Amendment.

Sincerely,

Melissa Reese-Thacker
Planning Manager

**Site Improvement Plan (SIP) Amendment application SP24-0003 and
Planned Development Amendment application ZR24-0001**

Planning Commission

We strongly object to the proposal to change the zoning for the Cornerstone Church property to allow a school to operate here and build townhomes and playing fields on the property.

The project narrative states: “Ensure redevelopment is harmonious with existing neighborhood characteristics in terms of quality, impacts, and scale. Galloway Response: The Change In Use will have minimal impacts on the existing neighborhood compared to the impacts of the existing church. A school and church share common impacts to surrounding areas.”

These last two sentences are simply incorrect. This proposal would be a huge change for both the Carriage Club and Centennial Ridge neighborhoods. The most compelling reason NOT to allow this is quite simply the activity level. It would change this property from basically one day a week activity on Sunday to a daily activity. Our residents already know to avoid this area on Sunday mornings as it is very difficult to exit the neighborhood at this location. To add daily traffic would be wrong.

This proposal entails both drop-off and pick-ups for potentially 208 cars in both the morning and evening at least five days a week. Even if there were carpools, there would be a huge increase in traffic on the already challenging intersection of Lone Tree Parkway and Lincoln Avenue (Lincoln).

During rush hour it is often quite difficult to turn left onto Lincoln from northbound Lone Tree Parkway. As a four-lane road, Lincoln traffic has precedence to Lone Tree Parkway traffic which makes sense. However, to add a daily use here on Lone Tree Parkway is simply inappropriate.

The SIP Amendment Application states: “The SIP Amendment application includes a traffic study and on-site vehicular circulation plan. A component of the on-site vehicular circulation plan is an operating plan and queueing analysis for pick-up/drop-off operations for the proposed school use.”

The fact that there will be an onsite vehicular circulation plan is simply irrelevant because the actual issue is getting cars to and from the school entrance on Lone Tree Parkway just south of Lincoln. This intersection cannot handle the increased traffic that this school will require both at rush hour in the morning and the beginning of rush hour in the evening. Even though the project narrative describes staggering times for drop-off and pick-up, they state that they are between 7:20 and 7:50 AM Monday through Friday and 3:30 to 3:45 PM Monday through Thursday with 3:45-5:30 PM times that staff leaves. Anyone who has tried to go west on Lincoln Avenue at rush hour will attest that this is absurd.

Safety is also a big concern here. With the Chabad Center across the street, the potential for accidents increases exponentially with a school sited at the Cornerstone Church property.

In addition, cars leaving the church property might try to avoid the light at Lone Tree Parkway and Lincoln by traveling east on Lone Tree Parkway to exit onto Lincoln Avenue. The eastern Lone Tree Parkway and Lincoln intersection is currently heavily trafficked at all times of day. When people try to turn left there, they often block the exit from the neighborhood. In addition, the Centennial Ridge Park to the east on Lone Tree Parkway often has large soccer games or other events that have many

parked vehicles on Lone Tree Parkway. This is simply an accident waiting to happen. We believe that this potential school would most certainly necessitate installing a traffic light on Lincoln at the eastern terminus of Lone Tree Parkway. And even that will not remediate the traffic issues at the western intersection of Lincoln and Lone Tree Parkway.

In addition, the noise of outside playing fields will affect the serenity of the surrounding walking paths. Adding paths will only accentuate this issue as the pedestrian traffic will increase too.

We strongly object to this potential zoning or use change and urge the Planning Commission not to recommend this proposal to the City Council. A traffic study and queuing study simply will not address the existing congestion at this intersection, nor will it address the affect this zoning change will have on the Centennial Ridge and Carriage Club neighborhoods.

Please consider how this use change of adding this large daily activity to an intersection or exit near your home would affect you and the value of your home.

Thank you for your consideration.

Martha and Roger Sippel
10524 Dacre Place
Lone Tree, CO 80124



Right of Way & Permits

1123 West 3rd Avenue
Denver, Colorado 80223
Telephone: 303.285.6612
violeta.ciocanu@xcelenergy.com

April 22, 2024

City of Lone Tree Community Development Department
9220 Kimmer Drive, #100
Lone Tree, CO 80124

Attn: Chuck Darnell

**RE: Centennial Ridge PD Amendment & SIP Amendment
Case #s ZR24-0001 and SP24-0003**

Public Service Company of Colorado's (PSCo) Right of Way & Permits Referral Desk has reviewed the documents for the proposed amendment to the Centennial Ridge Planned Development District, 2nd Amendment, and a Site Improvement Plan (SIP) amendment to allow for a change of use at the property located at 9941 Lone Tree Parkway. Please be aware PSCo owns and operates existing natural gas and electric distribution facilities within the property.

Though PSCo doesn't have any objections to the proposed amendment to the Centennial Ridge Planned Development District, 2nd Amendment, it determined it has **several conflicts** regarding the Site Improvement Plan. No structures (including retaining wall, the stairs, and the ramp) are allowed on the PSCo Easements. According to the Long-Term Conceptual Site Plan the sport courts and 4 Teacher Homes appear to be above the underground electric distribution facilities.

Note that proper clearances must be maintained including ground cover that should not be modified from original depths. Please contact Colorado 811 before excavating. Use caution and hand dig when excavating within 18-inches of each side of the marked facilities. Please be aware that all risk and responsibility for this request are unilaterally that of the Applicant/Requestor.

The property owner/developer/contractor must complete the application process for any new natural gas or electric service, or **modification to existing facilities, including relocation and/or removal** via xcelenergy.com/InstallAndConnect. It is then the responsibility of the developer to contact the Designer assigned to the project for approval of design details.

Additional easements may need to be acquired by separate document. The Designer must contact the appropriate Right-of-Way Agent.

Violeta Ciocanu (Chokanu)
Right of Way and Permits
Public Service Company of Colorado dba Xcel Energy
Office: 303-285-6612 – Email: violeta.ciocanu@xcelenergy.com



cityoflonetree.com | 303.708.1818
9220 Kimmer Drive Suite 100, Lone Tree, CO 80124

Referral Request for Ambleside School SIP amendment

4/25/2024

To whom it may concern,

Thank you for submitting your referral request to the City of Lone Tree for the proposed Centennial Ridge PD amendment and SIP amendment for the new Ambleside school. After further review of the application and the landscaping plans, more detailed information is needed to provide sufficient feedback. Specifically, I need to know specific species of trees, shrubs, plants, etc... that are slated to be planted. More detail is needed for any existing landscaping, for example, all existing trees should be on the plan, along with any trees that are to be removed. If mature trees need to be removed, then I will ask for at least a 2:1 ratio of replacement. Large mature trees should try to be saved, if possible. I will also need a tree preservation plan for all mature trees during construction, this should show protection efforts during construction.

The last comment is regarding the fencing, this should not affect existing trees, please place or construct the fence so any existing trees are not impacted.

Should you have any questions regarding these comments please don't hesitate to contact me.

Thank you,

Sam Waggener

Code Compliance Supervisor &

City Forester

720-509-1269

Chuck Darnell

From: Kyle Goudy
Sent: Friday, April 26, 2024 8:36 AM
To: Chuck Darnell
Cc: Kirk Wilson
Subject: Ambleside School

Follow Up Flag: Follow up
Flag Status: Flagged

Hey,

I walked the property, inside and outside, and overall, no major concerns. The building has good natural surveillance from the main entry and the front desk area. The front entry is a double entry, which is needed for a school.

The main area, from a CPTED prospective that could use improvement is territorial reinforcement. I saw on the plan they are adding a fence, which would be my main recommendation for this property. The hill and path behind the school creates places to hide and approach the school without being seen. A fence will help define the space and make it more secure.

I also noticed some power shut offs on the outside of the building on the west side near the basement entry. I see on the plans they are remodeling that area and I recommend the power boxes be secure or moved, so they cannot be tampered with.

I would recommend, if not already installed, for the lower (basement, garden level) windows to have a 3M film put on to slow down or stop people from being able to break the windows and gain access through those areas that are less visible.

Last recommendation is for additional security cameras outside. I saw a few already but they are needed in the west side play area on the Lincoln side.

This is just some quick recommendations, and I can always meet with the school to go into detail on any other areas of concern.

Thank you and let me know if you have any questions.



Kyle Goudy
Police Officer
Community Partnership Unit
9220 Kimmer Drive
Lone Tree, CO 80124
Office: 303 339-8150
Cell: 303 961-4943

May 1, 2024

City of Lone Tree
9220 Kimmer Dr., Suite 100
Lone Tree, Colorado 80124
Attn: Community Development

RE: Ambleside School - Change of Use (Application ZR24-0001)

To whom it may concern:

I am submitting this letter in opposition to this Change of Use application.

The location currently is used as a church which has traffic on Sundays but very minimal traffic during the weekdays when homeowners in the adjacent communities of Centennial Ridge and Carriage Club are leaving and returning from work. Traffic congestion at existing private schools throughout the Douglas County area are apparent for anyone who drives through those areas during drop off and pick up. While a Traffic Study was conducted, I feel it is inadequate to evaluate the traffic that will be consistent with the proposed use for the following reasons:

- The adjacent neighborhoods of Centennial Ridge and Carriage Club are limited ingress/egress neighborhoods which both rely solely on Lone Tree Parkway for access. Appropriate peak hours should have been studied to determine the safety issues for access with the increased traffic.
- The Peak hour traffic volumes were not accurately conducted for the times when staff arrival, student drop off, and student pick up will occur. The study should have included 6:30 am for staff and early arrivals as well as both the 12:00 – 12:45 half day pick up drop off and the 3:00 – 4:00 pm time frame for student pick up and staff departure.
- The survey of volumes was conducted on a single day in wintertime with a high temperature of 33 degrees with light snow in the forecast the following evening where many remote workers in the neighborhood would have stayed home. Thus, reducing the number of vehicles on the roads (Lincoln Avenue and Lone Tree Parkway).
- The “overall acceptable” LOS “C” at the west intersection and the LOS “E” and LOS “F” for peak hours for left turning vehicles at the east intersection are concerning before the increased traffic and may require the City of Lone Tree to install another traffic light, thus slowing down traffic on Lincoln Avenue.
- Lincoln Avenue was reviewed as “a four-lane section with turn lanes at major intersections” when in fact there is no right turn lane on the east-bound lane of Lincoln turning into Lone Tree Parkway where it is presumed the majority of traffic will come from.
- Lone Tree Parkway was reviewed as “a two-lane section with turn lanes at major intersections” but it does not have a right turn lane on the west intersection nor any marked turn lanes on the east intersection.
- Lincoln Avenue is a major thoroughfare for the City of Lone Tree, yet “available data suggested a decrease in growth in the area” and a reduced 0.5% growth rate was used for forecasting despite this being a major thoroughfare which accepts traffic from a significantly large area.

- Effective Storage is not defined in the study, but the queuing analysis forecasts the queues to be “within their effective storage.” This appears, from all information listed, to queue cars from Lone Tree Parkway south beyond the proposed school entrance, thus creating a traffic issue for exiting vehicles and traffic hazards for all vehicles entering the neighborhood from Lincoln Avenue which must cross the entrance to the proposed school.
- People tend to turn away from traffic when another option is presented and there is no indication on the study of the increased traffic at the east intersection for people attempting to turn left at the east intersection to escape the school parking lot faster than the west intersection light will allow.
- The study doesn’t seem to indicate or address the high likelihood of increased U-turns in the neighborhood by drivers turning right to exit the parking lot when traffic is backed up at the west intersection and then U-turning to get back to the light. This is very common at all other private and public schools.
- The study doesn’t address the lack of pedestrian crossings on both Lone Tree Parkway and Lincoln Avenue at the Powerline Trail behind Cornerstone Church which will also create traffic slowdowns but would be needed to support a school.

Schools also bring significant changes in noise levels, lighting, and activities in the neighborhoods. Student outdoor activities during the day and evenings will create nuisances this neighborhood and Highlands Ranch neighbors are currently not subjected to and cannot be addressed with increased spacing or green zones around the already existing building.

While the Galloway team responded in the Narrative that this “school would support residents of Lone Tree by offering a place to work, learn and play in the neighborhood in which they live” this is a false claim as the school is moving, with its full staff and students from another area into Lone Tree, thus creating a burden with very little opportunity or support of Lone Tree. In fact, the Douglas County School district may suffer from bringing in another private school as any students that are added to the population will likely be students that would have attended Douglas County Schools. Douglas County School district is currently the highest performing school district in the state of Colorado and moving this school from Arapahoe County to Douglas County may have a negative impact on those statistics.

The Centennial Ridge neighborhood is already home to the Chabad Jewish Center which creates traffic every weekday morning and afternoon with its day care services, as well as event traffic in the evenings, and worship traffic every Saturday. The Narrative compares activities of the Cornerstone Church, which only occurs on Sunday, to the proposed school as sharing “common impacts to the surrounding areas.” Yet the long-term plan for the site includes adding a sports field, a large view obstructing gymnasium, and a view obstructing townhome complex.

Additionally, I share a concern about the negative traffic impacts on the neighborhood’s ingress and egress which will decrease the home values.

I am opposed to this Change of use due to the significant impacts on traffic on a major thoroughfare in Lone Tree (Lincoln Avenue) and the negative impacts to the Douglas County School District as well as the neighborhood concerns of safety for ingress and egress for both Centennial Ridge and Carriage Club neighborhoods and request that the City of Lone tree deny this Change of Use.

Sincerely,

Dan Coxall
10046 Genesee Ct.
Lone Tree, CO 80124
(970) 391-9187

Decision Summary: Planned Development (PD) Amendment (application ZR24-0001).

- a. Include language for Planning Area A that would allow public and private schools as a permitting use.**
- b. Add language under general requirements to require a traffic study w/ any proposed change in use.**

1) Comments to consider for this application (application ZR24-0001)

- a. The project narrative states: "...that other public / private school use is allowed in other Planning Areas within the same PD zoning documents; however, they are subject to a Use by Special Review (USR) process with the City."
 - i. Why is a USR not being submitted with the required items below included w/ the application? Narrative requires submittal requirements include Sec. 16-21-120. - Narrative.

- (1)General project concepts;
- (2)Zoning of the land and compliance with the zoning requirements;
- (3)Overall impacts of the proposed use on the property and adjoining lands;
- (4)Compliance with the Comprehensive Plan;
- (5)Compliance with appropriate agencies and necessary permits;
- (6)Proof of water availability;
- (7)Method of wastewater treatment;
- (8)Type of method of fire protection;
- (9)Impacts on existing flora and fauna;
- (10)Impacts on air and water quality;
- (11)Impacts on peace and quiet of neighborhood;
- (12)Provision of buffering, including additional landscaping;
- (13)Impacts on City services and services provided by special districts and other providers within the City;
- (14)Legal description; and
- (15)Name and address of the owner, the developer if different than the owner and the person preparing the plan exhibit and site improvement plan.

- ii. Project narrative includes future phases and additional school build out plans. The City of Lone Tree Community Development website for application: Site Improvement Plan Amendment application (application SP24-0003) being concurrently review with this application ZR24-0001 states:

"Any future improvements beyond those shown in the current SIP Amendment application would be reviewed again in the future by the City as an additional SIP Amendment application."

The City should reissue applications SP24-0003 and ZR24-0001 to clearly state what is under review and the decision to be considered.

iii. Lone Tree Comprehensive Plan Analysis

1. *Promote a balanced mix and distribution of land uses in Lone Tree that also fosters a live, work, and play environment.* **Galloway Response:** The proposed permitted use of a school will balance the existing built out neighborhoods surrounding the subject property. The school would support residents of Lone Tree by offering a place to work, learn, and play in the same neighborhood in which they live.

The proposed school is private and open to employees, enrolled students, etc., not the public. The local resident would not benefit unless they became part of the private school. Local residents would suffer the negative impacts of increased traffic from the school. This could have secondary impacts on neighborhood safety, property, values, etc.

2. *Provide safe and convenient vehicular, pedestrian, and bicycle access and connections between neighborhoods and destinations throughout the City for people of all ages and abilities.* **Galloway Response:** The proposed school will be considered a Change In Use from the existing church on the subject property. The existing vehicular, pedestrian, and bicycle access and connections will remain for the neighborhoods and residents to enjoy for the foreseeable future. Furthermore, an additional requirement within the General Requirements of the PD will require the Change In Use to provide a Traffic Study that will include queuing analysis and on-site vehicular circulation analysis to ensure safety.

Adding 548 new daily trips to accommodate the 208+ students and 30+ staff member for the school does not constitute “safe and convenient vehicular, pedestrian, and bicycle access”. This data was taken from the traffic study provided with application concurrent application. Note the traffic study contained errors, poor assumptions, and misrepresentations that attempted to support the conclusion of no increase traffic concern from the proposed change in use from a church to a school.

3. *Encourage the location of institutional uses within or in proximity to residential neighborhoods as places for people to walk to, such as civic buildings, schools, and other places of assembly, day care facilities, and neighborhood commercial areas.* **Galloway Response:** The Change In Use from a church to a school will ensure that this policy will remain for the neighborhoods and residents to continue to enjoy

A private school would not be available to local community member unless they are employed or have enrolled students. Since this is a commuter school, very few if any local residents would have access or any benefit. As stated above, local residents would gain the impacts from increased traffic and the fall out that carries.

4. *Foster neighborhoods and distinct areas interwoven within the City that have their own unique identity. Galloway Response: The existing identity of the existing neighborhoods surrounding the subject property will remain. The proposed Change In Use for the school will only foster closer bonds and provide a stronger support for the community at large.*

What is the existing identity of the adjacent neighborhood? How will the school foster closer bonds and provide stronger support? Statements and claims require factual support.

5. *Support redevelopment that advances the objectives of safe, compact, mixed-use, and pedestrian and bicycle-friendly development and is consistent with the City's Design Guidelines. Galloway Response: The Change In Use/ Redevelopment of the existing church to a school support this policy as the City's Design Guidelines will be followed by the concurrent Major SIP Amendment which is reviewed by City Staff. Furthermore, the overall character of the area will not be changed and will provide enhanced new pedestrian/trail connections.*

Increased traffic will degrade the quality of the neighborhood and decrease safety for pedestrians, bicyclists, and local residents. New trails will not enhance existing public trails, trail being promoted by the application will be for private use associated with the private school.

6. *Encourage redevelopment that creates greater connections to local parks, plazas and other gathering spaces, and access by pedestrians, bicycles, automobiles, and transit users. Galloway Response: Additional new pedestrian/trail connections will be included during the concurrent Major SIP Amendment application submittal.*

New trails will not enhance existing public trails, trail being promoted by the application will be for private use associated with the private school.

7. *Ensure redevelopment areas have adequate infrastructure, facilities and services when deciding changes in land use. Galloway Response: There will be no change or stress on the existing infrastructure, facilities, and services within the subject property.*

Increased traffic will stress and deteriorate the existing road network. The existing system will not safely support an additional 548 new daily trips. Lack of turn lanes and inundated traffic during drop-offs and pick-ups will create traffic chaos of the existing road infrastructure.

8. *Ensure redevelopment is harmonious with existing neighborhood characteristics in terms of quality, impacts, and scale. Galloway Response: The Change In Use/ Redevelopment of the existing church to a school will be harmonious with the existing neighborhood. It is anticipated that the proposed school use will have less vehicle trips and traffic related impacts to the surrounding neighborhoods.*

Going from a church that had limited peak use one day a week on Sunday mornings to a school that will have peak uses Monday through Friday is a dramatic change that cannot be characterized as “harmonious”.

Traffic study provided in concurrent application states 548 new daily trips. How does this equate to “less vehicle trips”?

9. *Provide safe, well-defined circulation systems within the site that connect users directly to entryways, public spaces, adjoining uses, trails, transit, and other pedestrian and bike lane systems. Identify services and amenities within one-half mile of the site and design sidewalks and trails to access them. Galloway Response: The existing site provides access to trails and major sidewalks and on-road bike lanes. Additionally new pedestrian/trail connections will be included at the SIP stage.*

New trails will not enhance existing public trails, trail being promoted by the application will be for private use associated with the private school.

The dramatic increase in traffic will deter pedestrian and bicycle use.

Since this is a commuter school, little to no pedestrian and bicycle use would occur.

10. Create conditions that are conducive to walking, bicycling and transit use by fostering safe, walkable environments. *Galloway Response: The subject site is a prime example of multimodal options having the existing trails and major sidewalks and on-road bike lanes with plans to expand with new pedestrian/trail connections.*

New trails will not enhance existing public trails, trail being promoted by the application will be for private use associated with the private school.

The dramatic increase in traffic will deter pedestrian and bicycle use.

Decision Summary: Site Improvement Plan (SIP) Amendment application (application SP24-0003).

a. SIP Amendment to allow a change in use of an existing church use to a private school use.

1) SIP Amendment Application (ZR24-0001) Comments

- a. Overall the application is lacking detail and accurate information which speaks to wanting to just push the application through, not complete a credible product, and just doing the minimum with hopes that no one is paying close enough attention.
 - 1) The application should be denied or deemed incomplete based on lack of study, completeness, errors.
 - 2) Increase traffic will place a huge stress on the existing community, create unsafe conditions, and not be compatible with Lone Tress code and comp plan (see David Dean comments submitted on PD Amendment application).
 - 3) Local residence would not benefit from change in use. Local residents would bear the burden of increased traffic, unsafe walking and biking conditions, and negative impacts to real estate values.
- b. It is unclear if the school will have 208 or 225 students; data is inconsistent in the application.
- c. The traffic study was only completed for 1-day (12/12/23) from 0700-0900 and 1600-1800. This study did not capture the afternoon dismissal times or mid-day times on Friday. It also did not capture times for events outside of school hours that all schools experience (conference, arts, sports, etc.)
- d. Application states 175 trips in AM and only 31 in the PM. Where did ALL the kids and employees go at the end of the day?
 - 1) At 175 trips, minus 30 staff, that is 145 drop-offs in 30-minutes (0720-0750). That's about 12-seconds per drop off. I am not sure children, especially young children, can safely exist a car w/ their school bag, lunch, etc. and clear the car line. If not, then the car line gets backed up, drivers get frustrated, and the traffic flow is dramatically impacted. This is not captured in the study.
- e. Daily trip increase to 548, WOW!! What was the baseline for the church? This is a HUGE increase for current conditions since church traffic was typically only Sunday AM. What was the baseline use of the church compared to the proposed use? Need to document this to show the level of change to base the application claims of no change from church to school.
- f. What percent of nearby community is enrolled in the school? Application claims walker and biker use, adjacent community benefit use, jobs for locals, etc. At \$13k to almost \$16k a year seems like a school reserved for wealthy. If no nearby community enrollment or use this is a false/inaccurate claim.

- g. Claim nearby/adjacent community attend school, work there, etc. if so, why is there 548 NEW daily trips? Trips speak to Community school.
- h. Post speed limit for Lone Tree Parkway is 25 mph not 30 mph. False information provided in the application.
- i. Web data shows between approximately 90-150 students and there are 32 staff members listed on the school website. For full enrollment to 208 there would need to be an additional 6 more staff added to maintain the existing student teacher ration reported on the school web. School site doesn't show support staff such as custodians, medical, maintenance, Resource Officer, etc.
 - 1) Traffic study only accounts for 30 staff members.
- j. Traffic study does not account for the impact of after school events, a continuous stream of traffic from parents volunteering (school requirement of 6+ hours a month), student pick-ups for illness, appointments, etc.
- k. Application does not consider additional lighting impacts that a school would have on adjacent properties and community.
- l. Application does not consider additional noise impacts that a school would have on adjacent properties and community.
- m. What summer programs would the school offer? Nothing mentioned in the applications.
- n. Power line trail routinely floods at the bottom of the hill near the sidewalk connection to the dirt trail. How will increased development of the church site to a school build accommodate additional run-off and stormwater issue created? Please clarify.

May 2, 2024

TO: Mr. Chuck Darnell, Principal Planner, City of Lone Tree, Colorado

FROM: William and Sara Clendenning

As long-term residents of the Centennial Ridge neighborhood (since August 1992), at 10039 Genesee Ct, Lone Tree, we are very concerned about the current proposal to amend the authorized use of the Cornerstone Church location to include private school use.

This proposal is fraught with negative impacts to the Centennial Ridge, Carriage Club, Terra Ridge, and Cypress Greens neighborhoods as well as the City of Lone Tree as a whole.

TRAFFIC / SAFETY - Entry to the proposed school will be onto Lone Tree Parkway to the south of Lincoln.

1. The short semi-circle, 2-lane street is the only access in and out of Centennial Ridge and Carriage Club. There are approximately 500 homes in these two areas accessing this street on a daily basis.
2. The egress intersections already back up at various times during the day, mostly in the morning hours, when students would be arriving.
3. With a queue of cars lining up on Lone Tree Parkway, it will make it difficult or virtually impossible for the local residents to travel in and out of the area at those times.
4. Without a light at the eastern intersection of Lone Tree Parkway and Lincoln Avenue, this would be a huge safety issue as vehicles attempt to turn left onto westbound Lincoln Avenue. Before the traffic light was installed at the western intersection there were numerous traffic accidents and fatalities.
5. Seeing the traffic backups for SkyView Academy as far east as Wal-Mart and even Quebec provides a clear view that this situation would result in traffic queues on Lincoln Avenue, east and west. There are currently inadequate turning lanes to support this, therefore negatively affecting all traffic on Lincoln Avenue. Lincoln Avenue is the main thoroughfare moving cars to/from Highlands Ranch/ Lone Tree and I-25, already with significant volume and backups.
6. No doubt drivers will perform unsafe maneuvers to avoid the backups by doing U-turns in the middle of Lone Tree Parkway to get back to the light and avoid the eastern intersection without a light.
7. It would be a shame to widen the roads, or add lanes just to accommodate additional traffic over which the City has complete control by denying new use proposals as this one. The beauty of Lincoln Avenue between Highlands Ranch and Yosemite, with the landscaped islands, needs to be preserved. The City has worked hard over the years to provide beautiful streetscapes on the main roads within the city (Lone Tree Parkway, Lincoln Avenue and Yosemite).

BENEFITS

1. The application indicates that the local community will benefit from this school. We cannot see a single benefit that will be provided to us.

2. We suspect that the current 200+ attendees of the school mostly live outside of Lone Tree as this school is relocating from Arapahoe County. A private school will just be bringing their traffic into our city as well as additional noise with on-site activities.
3. We do not need a 'private' school in our neighborhood for any type of balance as indicated by Galloway's narrative...or to foster a closer bond and support for community. That is just a ridiculous statement on all levels. Having a nice, quiet community, without congestion, is what all of us want and is why we live in this community.
4. Use as a church had minimal impact on the community as it was attended mainly on Sunday when residents were not accessing Lone Tree Parkway at the same level as on a weekday. Parishioners arrived for an indoor service and departed at the end. They came in and out only once versus parents making 2 trips in and out of the area and queing. The narrative stating that the church and school have the same impact to a community is just false.
5. One of the greatest benefits we already have is that the City of Lone Tree has excellent school options for learning with Eagle Ridge / Lone Tree / Acres Green / Fox Creek Elementary Schools, Cresthill and Rocky Ridge Middle Schools and Highlands Rance / Rock Canyon High Schools. Douglas County is one of the highest performing school districts in the state of Colorado. Again, attempting to sway the approval based on offering learning isn't a case at all.

OPINION

1. Private schools such as this should locate within areas that are already zoned as such. The City and County planners identified school zones with more adequate access and open area buffers to not negatively impact residential communities.
2. A private school within our community adds no value to our properties. Instead it would most likely reduce our property values and the desire for new residents to move into Centennial Ridge and the City of Lone Tree. This would make it more difficult to sell our properties when the need arises.
3. Approving a use change for this property to include private school use does not align with the City of Lone Tree's 'thoughtful planning' that it is proud of since 1995.
4. The Cornerstone Church property is a beautiful building. The church was always a great neighbor to our community, and we hope another church will relocate to this property.

We request that the City of Lone Tree does not approve both applications currently being presented for approval by the Ambleside School. Site Improvement Plan (SIP) Amendment application (SP24-0003) and Planned Development (PD) Amendment (application ZR24-0001).

Thank you for your consideration.

William Clendenning

Sara Clendenning

May 2, 2024

TO: Mr. Chuck Darnell, Principal Planner, City of Lone Tree, Colorado

FROM: William and Sara Clendenning

As long-term residents of the Centennial Ridge neighborhood (since August 1992), at 10039 Genesee Ct, Lone Tree, we are very concerned about the current proposal to amend the authorized use of the Cornerstone Church location to include private school use.

This proposal is fraught with negative impacts to the Centennial Ridge, Carriage Club, Terra Ridge, and Cypress Greens neighborhoods as well as the City of Lone Tree as a whole.

TRAFFIC / SAFETY - Entry to the proposed school will be onto Lone Tree Parkway to the south of Lincoln.

1. The short semi-circle, 2-lane street is the only access in and out of Centennial Ridge and Carriage Club. There are approximately 500 homes in these two areas accessing this street on a daily basis.
2. The egress intersections already back up at various times during the day, mostly in the morning hours, when students would be arriving.
3. With a queue of cars lining up on Lone Tree Parkway, it will make it difficult or virtually impossible for the local residents to travel in and out of the area at those times.
4. Without a light at the eastern intersection of Lone Tree Parkway and Lincoln Avenue, this would be a huge safety issue as vehicles attempt to turn left onto westbound Lincoln Avenue. Before the traffic light was installed at the western intersection there were numerous traffic accidents and fatalities.
5. Seeing the traffic backups for SkyView Academy as far east as Wal-Mart and even Quebec provides a clear view that this situation would result in traffic queues on Lincoln Avenue, east and west. There are currently inadequate turning lanes to support this, therefore negatively affecting all traffic on Lincoln Avenue. Lincoln Avenue is the main thoroughfare moving cars to/from Highlands Ranch/ Lone Tree and I-25, already with significant volume and backups.
6. No doubt drivers will perform unsafe maneuvers to avoid the backups by doing U-turns in the middle of Lone Tree Parkway to get back to the light and avoid the eastern intersection without a light.
7. It would be a shame to widen the roads, or add lanes just to accommodate additional traffic over which the City has complete control by denying new use proposals as this one. The beauty of Lincoln Avenue between Highlands Ranch and Yosemite, with the landscaped islands, needs to be preserved. The City has worked hard over the years to provide beautiful streetscapes on the main roads within the city (Lone Tree Parkway, Lincoln Avenue and Yosemite).

BENEFITS

1. The application indicates that the local community will benefit from this school. We cannot see a single benefit that will be provided to us.

2. We suspect that the current 200+ attendees of the school mostly live outside of Lone Tree as this school is relocating from Arapahoe County. A private school will just be bringing their traffic into our city as well as additional noise with on-site activities.
3. We do not need a 'private' school in our neighborhood for any type of balance as indicated by Galloway's narrative...or to foster a closer bond and support for community. That is just a ridiculous statement on all levels. Having a nice, quiet community, without congestion, is what all of us want and is why we live in this community.
4. Use as a church had minimal impact on the community as it was attended mainly on Sunday when residents were not accessing Lone Tree Parkway at the same level as on a weekday. Parishioners arrived for an indoor service and departed at the end. They came in and out only once versus parents making 2 trips in and out of the area and queing. The narrative stating that the church and school have the same impact to a community is just false.
5. One of the greatest benefits we already have is that the City of Lone Tree has excellent school options for learning with Eagle Ridge / Lone Tree / Acres Green / Fox Creek Elementary Schools, Cresthill and Rocky Ridge Middle Schools and Highlands Rance / Rock Canyon High Schools. Douglas County is one of the highest performing school districts in the state of Colorado. Again, attempting to sway the approval based on offering learning isn't a case at all.

OPINION

1. Private schools such as this should locate within areas that are already zoned as such. The City and County planners identified school zones with more adequate access and open area buffers to not negatively impact residential communities.
2. A private school within our community adds no value to our properties. Instead it would most likely reduce our property values and the desire for new residents to move into Centennial Ridge and the City of Lone Tree. This would make it more difficult to sell our properties when the need arises.
3. Approving a use change for this property to include private school use does not align with the City of Lone Tree's 'thoughtful planning' that it is proud of since 1995.
4. The Cornerstone Church property is a beautiful building. The church was always a great neighbor to our community, and we hope another church will relocate to this property.

We request that the City of Lone Tree does not approve both applications currently being presented for approval by the Ambleside School. Site Improvement Plan (SIP) Amendment application (SP24-0003) and Planned Development (PD) Amendment (application ZR24-0001).

Thank you for your consideration.

William Clendenning

Sara Clendenning

May 2, 2024

RE: Ambleside School Change of Use and Centennial Ridge Planned Development Amendment

Dear City of Lone Tree,

The Centennial Ridge Homeowners Association (CRHOA) is very concerned about the proposed change of use which, if approved, would take place within our neighborhood at the Cornerstone Church location with the proposed Ambleside School - Change of Use and Centennial Ridge Planned Development Amendment.

This site in our neighborhood is currently in use as a church which has traffic on Sundays but very minimal traffic during the weekdays when homeowners in Centennial Ridge and Carriage Club are leaving and returning from work. Traffic congestion at existing private schools throughout the Douglas County area are apparent for anyone who drives through those areas during drop off and pick up times.

While a Traffic Study was conducted, we feel it is inadequate to evaluate the traffic that will be consistent with the proposed use for the following reasons:

- Centennial Ridge and Carriage Club are limited ingress/egress neighborhoods which both rely solely on Lone Tree Parkway for ALL access. Appropriate peak hours should have been studied to determine the safety issues for access with the increased traffic.
- The Peak hour traffic volumes were not accurately conducted for the times when staff arrival, student drop off, and student pick up will occur. The study should have included 6:30 am for staff and early arrivals as well as both the 12:00 – 12:45 half day pick up drop off and the 3:00 – 4:00 pm timeframe for student pick up and staff departure.
- The survey of volumes was conducted on a single day in wintertime with a high temperature of 33 degrees with light snow in the forecast the following evening where many remote workers in the neighborhood would have stayed home. Thus, reducing the number of vehicles on the roads (Lincoln Avenue and Lone Tree Parkway).
- The current “overall acceptable” LOS “C” at the west intersection and the LOS “E” and LOS “F” for peak hours for left turning vehicles at the east intersection are concerning before the increased traffic and may require the City of Lone Tree to install another traffic light, thus slowing down traffic on Lincoln Avenue and costing the City money.
- Lincoln Avenue was reviewed as “a four-lane section with turn lanes at major intersections” when in fact there is no right turn lane on the east-bound lane of Lincoln turning into Lone Tree Parkway where it is presumed the majority of traffic for this school will come from. The current traffic situation with the Lincoln Avenue/Quebec construction is a good indicator or back ups that can happen on Lincoln Avenue with any slowdowns as that traffic is routinely backed up past the Lone Tree Parkway light a mile away.
- Lone Tree Parkway was reviewed as “a two-lane section with turn lanes at major intersections” but it does not have a dedicated right turn lane on the west intersection nor any marked turn lanes on the east intersection.
- Lincoln Avenue is a major thoroughfare for the City of Lone Tree, yet “available data suggested a decrease in growth in the area” and a reduced 0.5% growth rate was used for

forecasting despite this being a major thoroughfare which accepts traffic from a significantly large area.

- Effective Storage is not defined in the study, but the queuing analysis forecasts the queues to be “within their effective storage.” This appears, from all information listed, to queue cars from Lone Tree Parkway south beyond the proposed school entrance, thus creating a traffic issue for exiting vehicles and traffic hazards for all vehicles entering the neighborhood from Lincoln Avenue which must cross the entrance of the proposed school.
- People tend to turn away from traffic when another option is presented and there is no indication on the study of the increased traffic at the east intersection for people attempting to turn left at the east intersection to escape the school parking lot faster than the west intersection light will allow.
- The study doesn’t seem to indicate or address the high likelihood of increased U-turns in the neighborhood by drivers turning right to exit the parking lot when traffic is backed up at the west intersection and then U-turning to get back to the light. This is very common at all other private and public schools.
- The study doesn’t address the lack of pedestrian crossings on both Lone Tree Parkway and Lincoln Avenue at the Powerline Trail behind Cornerstone Church which will also create traffic slowdowns but would be needed to support a school.
- The posted speed limit on Lone Tree Parkway is 25 MPH not 30 MPH.

We have the following responses to the Project Narratives for both the Ambleside School – Change of Use and the Centennial Ridge Planned Development Amendment:

- The Project Narrative states “...other public/private school use is allowed in other Planning Areas within the same PD zoning document; however, they are subject to a Use by Special Review (USR) process with the City.” Why is a USR not being submitted with the required items included with the application?
- The Project Narrative includes future phasing and additional school build out plans, including townhomes for teacher residences, a gymnasium, and a field, however it is unclear what is under review in these two applications (SP24-0003 and ZR24-0001) yet “any future improvements beyond those shown in the SIP Amendment application would be reviewed again in the future.” It is unclear what comments are expected at this time with this future phasing inclusion and what is expected to happen later.
- Galloway Response: The proposed permitted use of a school will balance the existing built out neighborhoods surrounding the subject property. The school would support residents of Lone Tree by offering a place to work, learn, and play in the same neighborhood in which they live.
 - The proposed school is private and open only to employees, enrolled students, etc., not the public. The local residents would not benefit unless they became part of the private school. The neighborhood would suffer the negative impacts of increased traffic from the school. This could have secondary impacts on neighborhood safety, property, values, etc.
 - It is also important to note that the school is moving, with its full staff and students from another area into Lone Tree, thus creating a burden with very little opportunity or support of Lone Tree. In fact, the Douglas County School district may suffer from

bringing in another private school as any local students that are added in the future to the population will likely be students that would have attended Douglas County Schools. Douglas County School district is currently the highest performing school district in the state of Colorado and moving this school from Arapahoe County to Douglas County may have a negative impact on those statistics.

- Galloway Response: The proposed school will be considered a Change In Use from the existing church on the subject property. The existing vehicular, pedestrian, and bicycle access and connections will remain for the neighborhoods and residents to enjoy for the foreseeable future. Furthermore, an additional requirement within the General Requirements of the PD will require the Change In Use to provide a Traffic Study that will include queuing analysis and on-site vehicular circulation analysis to ensure safety.
 - Adding 548 new daily trips to accommodate the 208+ students and 30+ staff members for the school does not constitute “safe and convenient vehicular, pedestrian, and bicycle access”. This data was taken from the traffic study provided with the applications and we’ve made our comments above about concerns with that traffic study.
- Galloway Response: The Change In Use from a church to a school will ensure that this policy [encouraging places to walk to] will remain for the neighborhoods and residents to continue to enjoy.
 - A private school would not be available to local community members unless they are employed or have enrolled students. Since this is a commuter school, very few if any, neighborhood residents would have access or any benefit. As stated above, local residents would gain the impacts from increased traffic and the fall out that carries.
- Galloway Response: The existing identity of the existing neighborhoods surrounding the subject property will remain. The proposed Change In Use for the school will only foster closer bonds and provide a stronger support for the community at large.
 - What is the existing identity of the adjacent neighborhood? How will the school foster closer bonds and provide stronger support? Statements and claims require factual support. We disagree with the Galloway Response as we are the existing neighborhood and so not see how this will foster any closer bonds or provide support for the community.
- Galloway Response: The Change In Use/ Redevelopment of the existing church to a school supports this policy [the objectives of safe, compact mixed-use and pedestrian bike friendly development] as the City’s Design Guidelines will be followed by the concurrent Major SIP Amendment which is reviewed by City Staff. Furthermore, the overall character of the area will not be changed and will provide enhanced new pedestrian/trail connections.
 - Increased traffic will degrade the quality of the neighborhood and decrease safety for pedestrians, bicyclists, and local residents thus degrading existing infrastructure. New trails will not enhance existing public trails, trails being promoted by the application will be for private use associated with the private school.
- Galloway Response: Additional new pedestrian/trail connections will be included during the concurrent Major SIP Amendment application submittal.

- Again, new trails will not enhance existing public trails. Trails being promoted by the application will be for private use associated with the private school.
- Galloway Response: There will be no change or stress on the existing infrastructure, facilities, and services within the subject property.
 - Increased traffic will stress and deteriorate the existing road network. The existing system will not safely support an additional 548 new daily trips based on the marginal traffic study completed. Lack of turn lanes and inundated traffic during drop-offs and pick-ups will create traffic chaos of the existing road infrastructure and major thoroughfare of Lincoln Avenue.
- Galloway Response: The Change In Use will have minimal impacts on the existing neighborhood compared to the impacts of the existing church. A school and church share common impacts to surrounding areas.
 - See comments on next bullet point.
- Galloway Response: The Change In Use/ Redevelopment of the existing church to a school will be harmonious with the existing neighborhood. It is anticipated that the proposed school use will have less vehicle trips and traffic related impacts to the surrounding neighborhoods.
 - These statements are injuriously false. The change from a church with limited peak use one day a week on Sunday mornings, to a school that will have multiple peak uses Monday through Friday is a dramatic change that cannot be characterized as “common impacts” or “harmonious”. The false claim that there will be less vehicle traffic is not supported by the marginal traffic study provided which clearly indicates 548 new daily trips. No study of the Sunday traffic from the church was conducted to support this claim.
 - Schools also bring significant changes in noise levels, lighting, and activities in the neighborhoods. Student outdoor activities during the day and evenings will create nuisances this neighborhood and Highlands Ranch neighbors are currently not subjected to and cannot be addressed with increased spacing or green zones around the already existing building. This is not “harmonious.”
 - The Centennial Ridge neighborhood is already home to the Chabad Jewish Center which creates traffic every weekday morning and afternoon with its day care services, as well as event traffic in the evenings, and worship traffic every Saturday.
 - The Centennial Ridge neighborhood is also home to the Centennial Ridge Park which hosts South Suburban Parks and Recreation sporting events which include increased traffic.
 - The Narrative compares activities of the Cornerstone Church, which only occurs on Sunday, to the proposed school as sharing “common impacts to the surrounding areas.” Yet the long-term plan for the site includes adding a sports field, a large view obstructing gymnasium, and a view obstructing townhome complex which will not be included in the HOA.
- Galloway Response: The existing site provides access to trails and major sidewalks and on-road bike lanes. Additionally new pedestrian/trail connections will be included at the SIP stage.

- New trails will not enhance existing public trails. Trails being promoted by the application will be for private use associated with the private school. The dramatic increase in traffic will deter pedestrian and bicycle use. Since this is a commuter school, little to no pedestrian or bicycle use would occur.
- Galloway Response: The subject site is a prime example of multimodal options having the existing trails and major sidewalks and on-road bike lanes with plans to expand with new pedestrian/trail connections.
 - Again, new trails will not enhance existing public trails. Trails being promoted by the application will be for private use associated with the private school. The dramatic increase in traffic will deter current pedestrian and bicycle use.

We have the following additional responses to the Applications:

- Overall, the applications are lacking detail and accurate information and are not complete credible products.
- The applications should be denied based on lack of study, completeness, and errors.
- It is unclear if the school will have 208 or 225 students.
- The traffic study was only completed for 1-day (12/12/23) from 0700-0900 and 1600-1800. This study did not capture the afternoon dismissal times or mid-day dismissal times as noted above. It also did not capture times for events outside of school hours that all schools experience (conference, arts, sports, etc.) or the impacts of inclement weather on the extended pick up/drop off times or the greater risk of accidents.
- The application states 175 trips in AM and only 31 in the evening. This is confusing and illogical.
 - At 175 trips, minus 30 staff, that is 145 drop-offs in 30-minutes (0720-0750). That's about 12-seconds per drop off. We do not believe that children, especially young children, can safely exit a car with their school bag, lunch, etc. and clear the car line in only 12 seconds. The car line will get backed up, drivers will get frustrated, and the traffic flow will be dramatically impacted. This is not captured in the study.
- Daily trips increase to 548. What was the baseline for the church traffic? We believe this to be a large increase from the church traffic one day a week.
- What percent of the nearby community is enrolled in the school? The application claims walker and biker use, adjacent community benefit use, jobs for locals, etc. with no indication of locality for any students. With tuition being \$13k to almost \$16k a year, this seems like a school reserved for affluent families, not in line with equity and diversity.
- The posted speed limit for Lone Tree Parkway is 25 mph not 30 mph.
- The web data shows between approximately 90-150 students and there are 32 staff members listed on the school website. For full enrollment to 208 there would need to be an additional 6 more staff added to maintain the existing student teacher ration reported on the school web. School site doesn't show support staff such as custodians, medical, maintenance, RSO, etc. Traffic study only accounts for 30 staff members.
- The Traffic study does not account for the impact of after school events, a continuous stream of traffic from parents volunteering (school requirement of 6+ hours a month), student pick-ups for illness, appointments, etc.

- The application does not consider additional lighting impacts that a school would have on adjacent properties and community.
- The application does not consider additional noise impacts that a school would have on adjacent properties and community.
- The application does not address what summer programs the school may offer.
- The power line trail routinely floods at the bottom of the hill near the sidewalk connection to the dirt trail. How will increased development of the church site to a school accommodate additional run-off and stormwater issues created?

We would recommend to the City of Lone Tree that it reject the applications for the Change of use and Planned Development Amendment due all these items above including but not limited to the significant impacts it will create on traffic on a major thoroughfare in Lone Tree (Lincoln Avenue), the negative impacts it will have to the surrounding neighborhood, the negative impacts to the Douglas County School District it may pose, as well as the neighborhood concerns of safety for ingress and egress for both Centennial Ridge and Carriage Club neighborhoods.

Thank you,

A handwritten signature in blue ink, appearing to read "Dawn Jewell".

Secretary on behalf of the

Centennial Ridge Homeowners Association

May 2, 2024

RE: Centennial Ridge Planned Development Amendment and Ambleside School – Change of Use

Dear City of Lone Tree,

We are writing to express our concern with the application for the Centennial Ridge planned development amendment and Ambleside school - Change of Use proposed at the Cornerstone Church in the Centennial Ridge community.

We are residents on Marin Court in the Centennial Ridge neighborhood. Our cul-de-sac is across from Cornerstone Church and houses the Chabad Jewish Center which provides daycare services, hosts night-time event services, and Saturday worship services. At the end of our cul-de-sac is Centennial Ridge Park which hosts sporting events in the evenings and weekends in the summer and weekend events in the spring and fall. We currently have what we believe to be the busiest cul-de-sac in all of Lone Tree despite having only fourteen houses. The addition of a school at the entrance to our busy cul-de-sac is going to make things exceedingly difficult for our street in particular and make Lone Tree Parkway significantly busier than demonstrated in the traffic study.

As you can see in the disappointing and insufficient traffic study, there is a lot of traffic on this cul-de-sac. It causes issues during inclement weather because this cul-de-sac is a low priority for plowing (as all cul-de-sacs should be) and yet it hosts a busy day care. We anticipate additional traffic into this cul-de-sac since we have seen with our own kids at Douglas County Schools, people pull off and use the cul-de-sacs for student drop off and pick up to avoid the lines created at the school itself.

We are also genuinely concerned about the future plan to install view blocking townhomes up against Lone Tree Parkway adjacent to other homes in our neighborhood on Rattlesnake. Our neighborhood has a certain closeknit charm with our lot sizes and home styles. Adding in this multifamily building will take away from the aesthetics of the neighborhood while not providing a housing solution that the City needs. These townhomes will be for select individuals who are employed and the school, thus building privileged residences which will not have the same standards as we adhere to in the surrounding HOA.

Another concern we have is to the larger neighborhood. Our neighborhood has limited access with only Lone Tree Parkway to enter or exit. This increased traffic is going to make it harder to get to and from our houses in Centennial Ridge and in Carriage Club. We feel the traffic study was poorly done and did not adequately look at traffic patterns during times that will be impacted by the school. They should have completed this on busy days, the right hours, a better weather day, and conducted a multi-day study.

We realize this sounds like a NIMBY complaint, but please try to imagine 548 new cars in front of your house every day. Try to imagine leaving your house and having to wait just to get out of your cul-de-sac due to the bumper-to-bumper traffic on a street that funnels everyone from two

neighborhoods to one area and has never seen this magnitude of traffic. With the only light being at the west side of Lone Tree Parkway, all traffic will be funneled to cross in front of our cul-de-sac.

We'd like the City to consider denying this request to move a school into our neighborhood, not just for the impact it will have on us neighbors, but because of the impact it will have on the City of Lone Tree with traffic on Lincoln Avenue. This will not bring any jobs or amenities to Lone Tree and will only create financial and commuter hardships for our citizens.

Sincerely,

A handwritten signature in black ink, appearing to read "Dana and Dawn Jewell". The signature is written in a cursive, flowing style.

Dana and Dawn Jewell

Centennial Ridge residents

10074 Armadillo Dr
Lone Tree, CO 80124-9719
May 1, 2024

TO: City Planner, City of Lone Tree
FROM: Mary Daugaard, Property Owner
RE: Planned Development Amendment - Cornerstone Church, 9941 Lone Tree Pkwy

I am opposed to the amendment that would allow the change in zoning for the property known as Cornerstone Church, 9941 Lone Tree Parkway, to allow for a private/public school (K-12), gymnasium, outdoor playing fields, and townhomes on that property. What we're being faced with right now should have been addressed prior to a contract being negotiated between the current owner and Ambleside School. Note that the current location of Ambleside School is Highlands Baptist Church and the property under questions is owned by First Baptist Church of Highlands Ranch. There can be no assumption on their part that this can just happen because of their religious affiliation.

TRAFFIC:

The .5 mile loop of Lone Tree Parkway that starts and ends on Lincoln supports traffic for Centennial Ridge and Carriage Club. These two neighborhoods contain 575 homes whose only way in and out is this .5 mile loop. There is no other way for these homes to get to Lincoln Avenue.

Today, the school has class sizes of approximately 15 student per class or 195 students total for K-12. There are also 34 teachers employed for K-8 and very likely a need to add more for the planned expansion to K-12. Ambleside school could add up to 250+ vehicles bringing the number of vehicles who need to use this loop Monday-Friday to 825+. The vehicles associated with Ambleside will merge from the staging area in the parking lot to Lone Tree Parkway in a very condensed window of time twice a day at the same time that current residents are leaving for work or taking their children to school. There is only one exit from the parking lot, and this is within 1/2 block of the light onto Lincoln Avenue. You also have the traffic bringing children to and from the Jewish Preschool on the corner opposite Cornerstone Church.

PROPERTY VALUES:

Residents of Centennial Ridge and Carriage Club have spoken to realtors who say this would negatively impact property values of our single-family homes because of traffic patterns, noise from the outside playground and soccer fields, and evening/weekend traffic from school events. The outdoor playing fields could also have lights and activity into the evening that would disrupt our quiet neighborhood.

Housing options proposed by Ambleside are not in sync with the existing single family homes. Currently, neither Centennial Ridge or Carriage Club have any townhomes, paired homes or apartment complexes. Property values for townhomes being proposed will be subsequently less than the median price of the single family homes in Centennial Ridge and Carriage Club.

May 3, 2024

To whom it may concern at City of Lone Tree:

Re: SP24-0003 and ZR24-0001

My name is Mary Kennedy, and I am a 24-year resident of Marin Court in Lone Tree. I am writing today to voice my deep concern over the Site Improvement Plan Amendment application SP24-0003 and Planned Development Amendment application ZR24-0001, Centennial Ridge Planned Development Amendment and Ambleside School - Change of Use.

Marin Court is on the northwest edge of Centennial Ridge and, although a cul-de-sac, already experiences above average traffic due to proximity to the intersection of Lone Tree Parkway and Lincoln Avenue, the Chabad Center at the top of the street, and proximity to the Centennial Ridge Park playing field where sports practices and games are held. The north side of Marin Court already backs to the heavily used Lincoln Avenue. Being directly across from the former Cornerstone Church adds to traffic and safety issues, however, it was manageable as a place of worship which isn't used daily - primarily Sunday mornings and occasionally during the week.

The speed limit of 25 miles per hour on the single-lane Lone Tree Parkway is rarely adhered to, and adding the addition of hundreds of cars multiple times a day five days a week creates a major safety issue for Centennial Ridge residents. The infrastructure of Lone Tree Parkway and Lincoln Avenue is already difficult to traverse and the turn lane into the neighborhood does not allow for much extra traffic. The turn lane into the current church parking lot could easily back up onto eastbound Lincoln Avenue during school drop-off and pickup windows, impeding the flow of traffic on the busiest road in Lone Tree. There is no street parking along Lone Tree Parkway, so during heavy traffic windows, Marin Court could be hugely impacted by parents parking on the street to avoid the carpool circle. There is no proposed bussing so each student would arrive and depart from cars.

There is no crosswalk between Marin Court and the current trails, paths, and sidewalks surrounding the former Cornerstone Church property. That, combined with excessive speeds, creates hazardous conditions for residents, pedestrians, and bicyclists, which will be greatly increased with the constant activity of a private school of this size.

The proposal to convert the site into a private K-12 school is not feasible in this location. In the past, some neighbors in the community attended Cornerstone church, limiting the extra traffic in a very busy area. A private school is only open to employees and select enrolled students, not the public and, therefore, local residents would not benefit. Instead, all the traffic and noise in the neighborhood adds huge stress to the existing community and increases safety concerns.

Thank you for your time reading feedback from the Centennial Ridge community. **I implore the City to deny SP24-0003 and ZR24-0001** to move a private school into our neighborhood because of the negative impact it will have on the residents. The City of Lone Tree will also be adversely affected as a private school in this location will create hardships for citizens who commute in this area, without any benefit of increased employment or amenities.

Sincerely,

Mary Kennedy
Marin Court Centennial Ridge resident

Concerns Regarding Ambleside School Proposal

Stephen Mikolajczak
Tonya Fallows
7561 Powderhorn Dr.

May 01, 2024

Major concerns

1. Stacking and parking vehicles

- a. Page 28 & 30 of the Traffic Study says 221 students. Page 2 of Narrative and page 41 of Traffic Plan says 208. It also says Ambleside Bylaws restrict number of students to 208 – but Bylaws can be changed. The Announcement video on Ambleside’s website talks about rapid growth in recent years and in the future. So how many students / cars will there really be in Fall 2024, in 2035, in 2074 (given this is a 100-year plan per the video)?
- b. Given the current location of the school (thus it’s geographic student draw) and per Traffic study page 28, most (70%) of the traffic will be from west and east bound Lincoln. This estimate seems low. How else does traffic get to the east and west LT Parkway and Lincoln intersections? Maybe a few who use LT Parkway north of Lincoln. These drivers will go south crossing over Lincoln, and if the traffic on the southside of LT Parkway (the subject area) backs up, they will be stuck on Lincoln blocking Lincoln traffic.
- c. Drop off is projected as 7:20 am to 7:50 am (30 minutes) which is during peak rush hour and obviously will heavily affect Centennial Ridge and Carriage Club residents who use either intersection to go to work or take their kids to school or go to Starbucks. The nature of drop-off is the arrival of most vehicles in a short period of time, “same time”. Because vehicles do not arrive in order to be stacked in the young student stalls, then the general stalls, and then drive-lane stacking ... there will be a backup of traffic onto Lincoln and on LT Parkway at the left turn lane into the parking lot - they will come from the east entry to bypass the west entry.
- d. Pick up is 3:30 pm to 3:45 pm (15 minutes) and is based on some students staying on campus for after-school activities. This time estimate seems too short. How many students will stay after school and is that number high enough to impact / spread out the pick-up time periods? And the nature of kids mingling with each other and teachers, putting on jackets and

backpacks, will spread out the time it takes them to get to their vehicle. The estimated 15-minute pick-up timeframe seems doubtful.

- e. Traffic Plan suggests a 2.3 occupancy per car. That's 1 driver and 1.3 (1.5) students. Car stacking suggests 31 vehicles stacked in main parking lot lane plus 43 parking stalls young students, plus approx. 57 available stalls in main lot (north). An additional 67 stalls are in the secondary lot (south) for staff, teachers, and driving age – but half of those will be eliminated for townhomes.
 - f. So there are 131 spaces available in the main lot (north). At 1.5 students per car there are enough stalls to accommodate 196 students out of 208 students minus 10 older students parking in the south lot. That leaves 28 students / 12 vehicles to stack on Lone Tree Parkway and east bound Lincoln.
 - g. However, not all drivers will stack as closely as the diagram on page 42 suggests. Plus, when a line of vehicles moves, they move 1 at a time = more gap spacing. Plus, there are vehicles in stalls that will cut in line. From my observations it is highly unlikely that more than half of the stalls will be used. I suggest 70 vehicles in stalls and 22 stacked = 92 vehicles x 1.5 = 138 students. Leaving 70 students in 59 vehicles stacked on the streets, at best.
2. Traffic @ Lincoln and west entry of Lone Tree Parkway intersection.
- a. Once the school's main lot is congested, vehicles will stack on LT Parkway and then back up on eastbound Lincoln eventually beyond the right turn lane and thus impacting the eastbound traffic in the south lane. Cars coming over the hill too fast are at risk of the unexpected traffic jam.
 - b. Some drivers may elect to bypass the backup on Lincoln and drive around the stacked vehicles and enter west LT Parkway in the left lane (Jewish Center). This is a hazardous move (note 2.c).
 - c. Westbound Lincoln has a left turn lane into west entry of LT Parkway at the traffic light that stacks 4 vehicles. They will use the east lane on the Parkway and will stop to cut into the west lane feeding into the main parking lot. This may lead to vehicles from that turn lane crossing east bound Lincoln getting stuck on Lincoln and blocking eastbound Lincoln traffic.
 - d. Traffic for pick up / drop off that use the LT Parkway east entry will back up east and west bound lanes of LT Parkway because of vehicles trying to get into the line going into the main lot.
 - e. There are public school buses that use this area that may be at risk with all the vehicles in the area and may experience delays.
3. Traffic @ Lincoln and east Lone Tree Parkway intersection.

- a. This intersection will be used by a few students from the east based on the Traffic Report. This will cause more back up on the left-hand turn lane on west bound Lincoln to the east entry of LT Parkway. I
 - b. Some vehicles coming from the west may elect to bypass the west entry of LT Parkway and go to the east entrance and proceed to the school. This will increase traffic going to the school along the Parkway and back lanes of LT Parkway from Marini Ct. to perhaps Centennial Ridge Park.
 - c. Traffic exiting the school parking lot driveway and ultimately heading east on Lincoln will be directed to go east to the east LT Parkway and Lincoln intersection. Some traffic will want to go west on Lincoln from here. They will need to cross eastbound traffic on Lincoln and merge in with westbound traffic. It is already very difficult and can be a long wait because of eastbound Lincoln traffic popping up on the hill. And some left turning vehicles won't move over to the left side of the lane and will block traffic attempting to go east on Lincoln. Happens all the time, and more traffic will make it worse.
 - d. LT Parkway has a park and public-school bus which means lots of school kids at the same time.
4. Townhomes
- a. Please make a special visit to residents on Rattlesnake that back to the subject property to get their concerns / feedback. Especially the home on the corner of LT Parkway & Rattlesnake, they use their backyard regularly. The southernmost or 2 southernmost units should be ranch style to reduce obstruction for this resident.

Moderate Concerns

1. If this proposal is approved, the school needs to hire Lone Tree's police / community patrol to handle traffic at both LT Parkway & Lincoln intersections until the school parents / drivers and the neighborhood figure out how to best navigate these intersections.
2. Vehicle Exhaust Pollution during drop-off & pick-up
 - a. Is there a study that projects how much of an increase in vehicle exhaust?
 - b. The residents nearby should be provided with an opportunity to express concerns because of their health issues.
3. Noise during the day, day-sleepers.
 - a. The school is in the NW corner of Centennial Ridge and we are in the SE. At that distance we can hear the Baptist Church kids playing outside. Concern is the disturbance for day sleepers who work at night.

4. Pedestrian and Bicycles

- a. In my opinion based on using the west Lincoln Lone Tree Parkway and nearby trails, I doubt parents will allow their children to walk or bike through that intersection and thus will not impact amount of drop off and pick up traffic.

Chuck Darnell

From: Brian Friedman <brianjayfriedman@yahoo.com>
Sent: Monday, April 1, 2024 9:47 PM
To: Chuck Darnell
Subject: 9941 Lone Tree Parkway - Amendment in Centennial Ridge

[You don't often get email from brianjayfriedman@yahoo.com. Learn why this is important at <https://aka.ms/LearnAboutSenderIdentification>]

Hello Chuck!

Hope all is well? I did submit my questions via the website, but I do have a very serious concern if the City allows Townhomes on the site (the 4 being proposed for teachers). Does the City have a stance on this request by the developer?

Centennial Ridge and adjacent Carriage Club are 100% single family homes. Allowing Townhomes, even 4, will impact the character of the neighborhood, plus will look entirely out of place like the City forgot about a master plan.

Thanks!

Brian Friedman
10044 Armadillo Dr

Chuck Darnell

From: Erica Maciel <emaciel2@yahoo.com>
Sent: Monday, April 1, 2024 9:06 PM
To: Chuck Darnell
Subject: Fw: Centennial Ridge Follow up to the City's email

You don't often get email from emaciel2@yahoo.com. [Learn why this is important](#)

Hi Chuck,

I hope this note finds you doing well. I am very concerned about these plans. What do I need to do to oppose this? I am not okay with them building townhomes nor am I ok with yet another private school when they plan to build townhomes on the property and bring an enormous amount of traffic to our neighborhood. Has anyone given any consideration to the fact that we have so many schools in the area? How are they legally allowed right now to be operating a school?

Thanks for any direction you can provide.

Warm wishes,

Erica Maciel

----- Forwarded Message -----

From: Jorge Alberto Maciel <jmaciel2@hotmail.com>
To: Erica Maciel <emaciel2@yahoo.com>
Sent: Monday, April 1, 2024 at 06:51:07 PM MDT
Subject: Fwd: Centennial Ridge Follow up to the City's email

Get [Outlook for iOS](#)

From: Shawna Allen <donotreply@appfolio.com>
Sent: Monday, April 1, 2024 4:05:00 PM
To: jmaciel2@hotmail.com <jmaciel2@hotmail.com>
Subject: Centennial Ridge Follow up to the City's email

Hi all,

Apparently when I copied over the body of the email from the City to our system, the hyperlink that was imbedded in the email did NOT come through. I have copied the links below.

Full Details:

<https://cityoflonetree.com/projects/centennial-ridge-planned-development-amendment/>

Site Improvement Plan (SIP)

<https://cityoflonetree.com/projects/ambleside-school-change-of-use/>

We are sending this out just for information, if you want to talk to the City about your concerns/ questions regarding this. We do not own this land, it is where the church used to be. They have vacated that lot and this is what they would like to do with it.

Thanks and have a great day....

Shawna Allen
303-779-0789

Chuck Darnell

From: Rob Tapparo <rob_80124@yahoo.com>
Sent: Monday, April 1, 2024 4:50 PM
To: Chuck Darnell
Subject: Cornerstone Church Future Use

[You don't often get email from rob_80124@yahoo.com. Learn why this is important at <https://aka.ms/LearnAboutSenderIdentification>]

Chuck,

I see plan views for the project, what I don't see are elevation views of the future proposed items -such as the gymnasium and teacher housing.

In addition to those elevations, how about any elevation showing type of fencing, regrading plans...

Are these available? If not why?

Regards,
Robert Tapparo
Sent from my iPhone

Chuck Darnell

From: Dick Thomas <rawhidet@aol.com>
Sent: Saturday, April 6, 2024 9:23 AM
To: Chuck Darnell
Subject: Re: Comment attachment

Follow Up Flag: Follow up
Flag Status: Flagged

You don't often get email from rawhidet@aol.com. [Learn why this is important](#)

Thanks for the reply Chuck, and no big thing on the delay.

The comments I was offering: We have absolutely no problem with a religion based school in our neighborhood and would say that the church has provided a very positive influence overall. Our concern lies in the growth of traffic, which will occur at peak travel times in the morning and afternoon. Unless there are changes made to the current lanes, there will be serious bottlenecks on Lincoln Avenue as well as Lone Tree Pkwy., as 150-175 cars drop off and pick up during those hours. I realize the city is conducting a “study” but I don’t have a lot of confidence in that bureaucracy. Thank you,
Dick and VickieThomas

[Sent from the all new AOL app for iOS](#)

On Friday, April 5, 2024, 6:43 AM, Chuck Darnell <chuck.darnell@cityoflonetree.com> wrote:

Hi Dick,

I'm sorry you were having issues providing comments in our online comment document/form. Were you trying to submit comments on a development project going on in the City of Lone Tree?

If so, please feel free to just email your comments directly to me. I did not see any attachment on your previous email either, so if it is easier, you can just email your comments directly to me.

Thanks,
Chuck

Chuck Darnell
Principal Planner
9220 Kimmer Drive
Lone Tree, CO 80124
720-509-1273

-----Original Message-----

From: Dick Thomas <rawhidet@aol.com>

Sent: Tuesday, April 2, 2024 4:54 PM

To: Chuck Darnell <chuck.darnell@cityoflonetree.com>

Subject: Comment attachment

[You don't often get email from rawhidet@aol.com. Learn why this is important at <https://aka.ms/LearnAboutSenderIdentification>]

Your comment document won't accept my verbiage, even though the email and address is accurate, which it indicates aren't.

Dick

Chuck Darnell

From: Don Deckard <DonDeckard@outlook.com>
Sent: Saturday, April 6, 2024 9:52 AM
To: Chuck Darnell
Subject: Ambleside Private Christian School Proposal

Follow Up Flag: Follow up
Flag Status: Flagged

You don't often get email from dondeckard@outlook.com. [Learn why this is important](#)

Hi Chuck,

I live in Carriage Club and was very concerned to learn of this proposed project. Lone Tree Parkway is already backed up with traffic in the morning and I can't imagine the mess that will be caused by adding hundreds of cars twice a day for drop off and pick up.

If this was a public school that had children from the surrounding neighborhood going to it that would be one thing but as a Private School it will be attracting students that will need to be dropped off and picked up. As a resident that uses Lone Tree Parkway as my only exit from my neighborhood I am totally opposed to this project.

Thank you for the opportunity to express my concerns.

Kind regards,

Donald Deckard
7940 Witney Place
Lone Tree, CO 80124
720-243-1713

Sent from my T-Mobile 5G Device
Get [Outlook for Android](#)

Chuck Darnell

From: WILLIAM Clendenning <bclendenning@comcast.net>
Sent: Thursday, May 2, 2024 7:14 PM
To: Chuck Darnell
Subject: Cornerstone Church Proposal
Attachments: City of Lone Tree - School proposal May 2024.docx

You don't often get email from bclendenning@comcast.net. [Learn why this is important](#)

Mr. Darnell,

The purpose of this email is to provide you with our comments and position regarding the proposed redevelopment of the Cornerstone Church property.

Thank you for taking time to review the attached letter. And considering our thoughts about the proposed planned development amendment.

Regards, Bill & Sara Clendenning

May 2, 2024

TO: Mr. Chuck Darnell, Principal Planner, City of Lone Tree, Colorado

FROM: William and Sara Clendenning

As long-term residents of the Centennial Ridge neighborhood (since August 1992), at 10039 Genesee Ct, Lone Tree, we are very concerned about the current proposal to amend the authorized use of the Cornerstone Church location to include private school use.

This proposal is fraught with negative impacts to the Centennial Ridge, Carriage Club, Terra Ridge, and Cypress Greens neighborhoods as well as the City of Lone Tree as a whole.

TRAFFIC / SAFETY - Entry to the proposed school will be onto Lone Tree Parkway to the south of Lincoln.

1. The short semi-circle, 2-lane street is the only access in and out of Centennial Ridge and Carriage Club. There are approximately 500 homes in these two areas accessing this street on a daily basis.
2. The egress intersections already back up at various times during the day, mostly in the morning hours, when students would be arriving.
3. With a queue of cars lining up on Lone Tree Parkway, it will make it difficult or virtually impossible for the local residents to travel in and out of the area at those times.
4. Without a light at the eastern intersection of Lone Tree Parkway and Lincoln Avenue, this would be a huge safety issue as vehicles attempt to turn left onto westbound Lincoln Avenue. Before the traffic light was installed at the western intersection there were numerous traffic accidents and fatalities.
5. Seeing the traffic backups for SkyView Academy as far east as Wal-Mart and even Quebec provides a clear view that this situation would result in traffic queues on Lincoln Avenue, east and west. There are currently inadequate turning lanes to support this, therefore negatively affecting all traffic on Lincoln Avenue. Lincoln Avenue is the main thoroughfare moving cars to/from Highlands Ranch/ Lone Tree and I-25, already with significant volume and backups.
6. No doubt drivers will perform unsafe maneuvers to avoid the backups by doing U-turns in the middle of Lone Tree Parkway to get back to the light and avoid the eastern intersection without a light.
7. It would be a shame to widen the roads, or add lanes just to accommodate additional traffic over which the City has complete control by denying new use proposals as this one. The beauty of Lincoln Avenue between Highlands Ranch and Yosemite, with the landscaped islands, needs to be preserved. The City has worked hard over the years to provide beautiful streetscapes on the main roads within the city (Lone Tree Parkway, Lincoln Avenue and Yosemite).

BENEFITS

1. The application indicates that the local community will benefit from this school. We cannot see a single benefit that will be provided to us.

2. We suspect that the current 200+ attendees of the school mostly live outside of Lone Tree as this school is relocating from Arapahoe County. A private school will just be bringing their traffic into our city as well as additional noise with on-site activities.
3. We do not need a 'private' school in our neighborhood for any type of balance as indicated by Galloway's narrative...or to foster a closer bond and support for community. That is just a ridiculous statement on all levels. Having a nice, quiet community, without congestion, is what all of us want and is why we live in this community.
4. Use as a church had minimal impact on the community as it was attended mainly on Sunday when residents were not accessing Lone Tree Parkway at the same level as on a weekday. Parishioners arrived for an indoor service and departed at the end. They came in and out only once versus parents making 2 trips in and out of the area and queing. The narrative stating that the church and school have the same impact to a community is just false.
5. One of the greatest benefits we already have is that the City of Lone Tree has excellent school options for learning with Eagle Ridge / Lone Tree / Acres Green / Fox Creek Elementary Schools, Cresthill and Rocky Ridge Middle Schools and Highlands Rance / Rock Canyon High Schools. Douglas County is one of the highest performing school districts in the state of Colorado. Again, attempting to sway the approval based on offering learning isn't a case at all.

OPINION

1. Private schools such as this should locate within areas that are already zoned as such. The City and County planners identified school zones with more adequate access and open area buffers to not negatively impact residential communities.
2. A private school within our community adds no value to our properties. Instead it would most likely reduce our property values and the desire for new residents to move into Centennial Ridge and the City of Lone Tree. This would make it more difficult to sell our properties when the need arises.
3. Approving a use change for this property to include private school use does not align with the City of Lone Tree's 'thoughtful planning' that it is proud of since 1995.
4. The Cornerstone Church property is a beautiful building. The church was always a great neighbor to our community, and we hope another church will relocate to this property.

We request that the City of Lone Tree does not approve both applications currently being presented for approval by the Ambleside School. Site Improvement Plan (SIP) Amendment application (SP24-0003) and Planned Development (PD) Amendment (application ZR24-0001).

Thank you for your consideration.

William Clendenning

Sara Clendenning

Chuck Darnell

From: Jamie Lynn Cooke <jamielkcooke@yahoo.com>
Sent: Thursday, May 2, 2024 8:52 PM
To: Chuck Darnell
Subject: Concerns About Planned Development Amendment Applications ZR24-0001 and SP24-0003

You don't often get email from jamielkcooke@yahoo.com. [Learn why this is important](#)

Hi Chuck,

We are homeowners at 10055 Genesee Court in Lone Tree and we are strongly opposed to Planned Development Amendment Applications ZR24-0001 and SP24-0003. The infrastructure at that site is unable to support the substantial increases in traffic and noise that will result if it becomes a school zone. The traffic study that they did was alarmingly insufficient. There are several other incorrect and misleading statements in these proposals that are detailed in the letter that the Centennial Ridge Homeowners Association will be sending to you.

We request that you require these proposals to be resubmitted with correct information that represents the actual impact this will have for all residents in our area.

Please contact me at 720 456 8434 if you would like additional information.

Kind regards,

Jamie and David Cooke

Chuck Darnell

From: anikmake@gmail.com
Sent: Friday, May 3, 2024 6:11 PM
To: Chuck Darnell
Subject: Ambleside School
Attachments: CSBC to School Proposal.pdf

You don't often get email from anikmake@gmail.com. [Learn why this is important](#)

Dear Mr. Darnell,

I am a long-time resident of Centennial Ridge long before the City of Lone Tree existed or the Southern Conference Baptist Church.

I oppose the change of use of the church building to a private school that in theory will only be 200 students. I have long experience with charter schools, and they all start small and then grow. Having been through 3 charter school locations and experienced the joy of carpools twice each day I can assure you this proposed school will destroy our neighborhood. Please take a moment to read my thoughts in the file attached.

Thank you,

Nick Komninos
7343 Rattlesnake Drive
720-299-1589

My name is Nick Komninos, and I was a resident of Centennial Ridge long before the Cornerstone Baptist Church was founded and subsequently expanded or even the city of Lone Tree was incorporated.

My house was the fifth house from the primary urbanization line of the metro area before construction began on Carriage Estates.

Traffic did not exist when we first moved to this neighborhood but that started to change especially when the Carriage Estates community next to us was finished and Target and Safeway together with all the apartments around them were built. I remember having to petition Douglas County to put a traffic light at the intersection of Lone Tree Pkwy and Lincoln because it was impossible to turn left going west from LT Pkwy to Lincoln. After a horrendous accident when an SUV ended upside down in the daycare yard they did.

This is the same intersection that hundreds of vehicles will have to use morning and afternoon and in between accessing the proposed school. The traffic will be unbearable for the residents of CR and Carriage Estates who use this traffic light to go west, and possibly very difficult for vehicles to exit the school lot.

This neighborhood was not designed for a huge commercial enterprise. The original church was a small building that kept on expanding and adding wings and other sections. Even the church now is a problem for the neighbors who back up to the parking lot of the church when the church has late evening events and people's living rooms and bedrooms get illuminated by headlights and gas from exhaust fumes. This issue of exhaust fumes will rise exponentially because of the extended idling of cars in carpool lines in and out. The air quality will diminish because of the cluster of vehicles in line.

As a back-of-the-envelope calculation, if Lone Tree Pkwy just south of Lincoln is full of cars waiting to enter and the parking lot is also full of cars waiting to drop off their students, this number is approximately 22 cars up to the entrance of the building. From the entrance to the exit by Marin Ct, the number of possible cars is about 13. Assuming a vehicle can exit the parking lot and go either left or right every 15 seconds, the rate at the lot emptying is 195 seconds but the rate the exit column fills, is double that because it takes 30 seconds for a small child to be unstrapped, exit the vehicle and the vehicle safely move ahead. Filling the parking lot and having the kids walk to the building is unsafe and it will have bottlenecks in and out.

So, the throughput will be about half a minute per car if the lot can empty at the same rate, which is 100 to 150 minutes for 250 cars if all is perfect. 150 minutes of idling is 2.5 hours early in the morning and it will be double that in the afternoon because all these cars will not be able to exit on Lincoln fast enough with the volume of traffic on it and the duration of the traffic light. So Centennial Ridge will become a gas chamber.

Moreover, the question is where will the rest of the cars be? If the cars on LT Pkwy south of Lincoln and in the parking lot are 22, the cars at the exit are 13, where are the rest? On Lincoln, east and west of LT Pkwy as well as on LT Pkwy North and possibly south of Lincoln? This picture will be a great Far Side Cartoon with the title: Carpool Nightmare.

Additionally, the noise of this carpool will add to the already high background coming from Lincoln. We used to be able to sit on our back deck and only hear the wind moving the leaves and occasional birds. Now it's only traffic. Noise pollution is an environmental stressor, and so is car exhaust and tire and

brake dust that will fill our homes and lungs because all these cars will be moving with their brakes constantly on.

In addition to the traffic nightmare which will destroy the character of our neighborhood, the noise from school recesses will be serenading everyone that is within 100 yards of the school as is already the case now.

Approving this school is not going to benefit the residents of Centennial Ridge, it will reduce the quality of life and add a lot of stress getting in and out of our neighborhood which does not have safe intersections due to the terrain and drivers who speed and run the red light on Lincoln often.

This proposed school is a commercial enterprise, it is not in the public interest and its approval will irreparably harm the residents of Centennial Ridge.

I have been involved with three Charter school locations and I know carpools are much slower than any theoretical calculation or study. The known unknowns are enough to derail the estimates, however, the unknown unknowns as Secretary Rumsfeld used to say can turn the best-case scenario into chaos.

I am opposed to any change in the use of the Church building, which should never have been allowed to expand in the first place. I was invited to the breaking ground ceremony and had excellent relations with the pastor who was in charge, as a member of the CR-HOA BOD when the church was small. We had HOA meetings in the church, and they always wanted a good neighbor relationship with us the neighbors.

This school will not be a good neighbor to Centennial Ridge.

Centennial Ridge, Ambleside School

Resident concerns over change from Church to School

1. Concerns over the increased heavy volume of traffic during morning drop-off times and afternoon pick-up times. This could impose traffic back up on Lone Tree Parkway between the traffic light and the access driveway.
2. There has been no mention regarding eligible drivers driving to and from this school. It seems in most surrounding schools those drivers drive to school and park on the resident streets during school hours. This would increase congestion in the nearby neighborhoods. This would also occur during special events at the school when overflow parking is needed.
3. By adding Sport's fields and outdoor Arena's this would generate increased noise levels that would have an impact on the nearby residents.
4. The planned future building of condominiums on the property for teacher housing should not be allowed without a zoning change. Is there something we are missing for this to take place when the surroundings homes are zoned single family?

Jeffrey Tatnall

7441 Powderhorn Dr.

Lone Tree, CO.80124

jeffreytatnall@comcast.net

Chuck Darnell

From: Rick Solomon <dirtbag918@aol.com>
Sent: Friday, May 17, 2024 10:45 PM
To: Chuck Darnell
Subject: Ambleside School - second review

I live in Terra Ridge, the neighborhood directly north across Lincoln.

Impacts I anticipate are to traffic, and I had previously requested a copy of the traffic study when available to assess. It has not been provided.

Creating a school along a major thoroughfare will impact through traffic, particularly in AM peak hour. Should a school zone be established here, traffic will be slowed to a crawl, similar to what occurs near St Mary's Academy on University. Whereby Lincoln is necked down from 3 lanes to 2, I anticipate through-traffic impacts.

Furthermore, students who walk to school will utilize the signal at Lone Tree Parkway, which will need additional crossing (phasing) time also impacting through traffic. To avoid any jaywalking, a fence along Lincoln is recommended to inhibit this dangerous practice.

I see no significant impact of the change of use, as long as it is safe. I do not support a new access on Lincoln. The flanking Wildcat Ridge Regional Trail lacks a grade separated crossing of Lincoln, and a safe over or underpass should be considered by the City for both students and recreational users.

Wynne Shaw
7966 Witney Place, Carriage Club
Lone Tree, CO 80124
(303)523-9374
wynneshaw@gmail.com

May 24, 2024

To Whom it May Concern:

I am opposed to approval of a “Use by Special Review” zoning change that would allow a private school to replace the existing church located at the west intersection of Lone Tree Parkway and Lincoln Avenue.

First, I will state that if the entrance to the property were moved to the west side of the property with access directly from Lincoln Avenue, and the entrance off Lone Tree Parkway was closed off, my objections to all but the sports field lighting and townhomes would disappear.

Without moving the entrance point to the property, my opposition to the project are because of the impacts to residents of the Carriage Club and Centennial Ridge neighborhoods caused by the additional levels of heavy traffic as follows:

- traffic congestion at both the east and west intersections of Lone Tree Parkway and Lincoln Avenue pollution from idling cars during pick up, drop off and queueing
- noise during drop off, pick up, and from the courts and sports fields
- light pollution from the courts and sports fields
- pedestrian and cyclist safety for residents of the neighborhoods, residents or visitors using Centennial Ridge Park
- safety of the pre-school children across the street

With the queuing plan as stated, a car with a 10th grader and an 8th grader would circle twice in the morning (in order to drop off one child at 7:20 and the other at 7:40am), would have to idle their vehicle as they wait at the edge of the road, then U-Turn in the neighborhood, and sit in traffic to circle through for drop-off again. It is also possible the driver would drop the child scheduled for 7:40am drop off at the roadside to walk through traffic and the drop off area on their own, when it's their time to enter the school. There are two round trips at the intersection or traffic driving through the neighborhood and pollution issues from idling, or safety issues for their second child, with this scenario.

I believe the applicant has understated the neighborhood impact, when they say, “The *Change In Use* will have minimal impacts on the existing neighborhood compared to the impacts of the existing church.”

- 1) The church’s traffic happened only one day of the week, a non-workday, and not when residents are incoming and exiting the neighborhood from their workouts, appointments or for work. As a church, people drive in and park, then leave after the church service—a single round trip for an event, one day per week; with the school model, there are two trips through the intersection for every drop off in the morning, and another two trips for every pick up at lunch time, after school, or after sports, and the traffic happens 5 to 7 days a week.

- 2) When churchgoers enter the parking lot on Sunday and park, there's no idling or drive-through motion of traffic associated with a drop off/pick up scenario, plus adults or adults with families are more visible and more cautious with traffic than young people alone.

The traffic projections may underestimate the neighborhood impact as well. First, I believe the characterization that many neighborhood kids would walk to bike to this private school may be exaggerated. I would ask the applicant how many K-12 aged kids live in Carriage Club and Centennial Ridge today, and of those, how many have a high probability of changing from their existing school to this private school (likely between 5th and 6th grade and 8th and 9th grade)? But, if the overview is accurate as stated, that there would be a projected 2.3 occupants per vehicle and one of those would be a driver, there would be 160 cars making round-trip drop-offs (320 trips) and round-trip pick-ups (320 trips) each day for 208 students. The balance of 121 trips would be represented by cars with 2 students at different drop-off times and the single arrival and departure per day by building staff. Totaling 761 new weekday trips each day, that is a considerable amount of additional traffic at both the east and west entrances to the neighborhoods, not to mention traffic that will be generated for weekend or evening scheduled sports events or practices.

The traffic study states, "The proposed site development would generate, upon completion and full occupancy, 175 new weekday AM and 38 new weekday PM peak hour vehicle trips as well as 548 new weekday daily trips." That set of figures indicates a total of 761 new weekday trips. To put it another way, that would almost be like putting the traffic from another neighborhood the size of Carriage Club through the intersections each day, half of that traffic occurring at peak times. That will be too large a burden for both Carriage Club and Centennial Ridge residents to sustain.

The City of Lone Tree has seen from the example of Ascent Classical Academy, that traffic and queueing projections were not accurate, and that parents do not follow the instructions of the school during drop off and pick up. In the case of Ambleside as proposed, both the east and west neighborhood entrances will be overburdened with cars attributable to drop-offs and pick-ups. So, although I hope this "Use by Special Review" zoning change is not approved, if for some reason it is, I believe a condition of approval must be that the applicant is required to fully fund a traffic signal at the east entrance to the neighborhoods and long-term traffic direction people at the school site in the same manner as was required of In and Out Burger.

As an additional observation, the differences in public infrastructure for power, water and sewer, fire and police that the building team will "continue to evaluate," logically will be different for a building with 208 students plus staff 5 days per week for 10 hours per day than for the church with 5 hours of full occupancy on Sundays and minimal usage during the week. Infrastructure changes like those will create even more traffic problems for neighborhood residents.

My final comment is in opposition to the 4 townhomes proposed for the parking lot, overlooking the yards of homes in Centennial Ridge. These townhomes are not in keeping with the character, quality, impact and scale of the existing neighborhood and should not be approved.

Thank you for your opposition of this zoning change,

Wynne Shaw